

RT70

Yanmar® 4TNV98CT, equipped with tires or tracks

Operator's Manual



CMW®

Issue 2.0
Original Instruction

053-3307

Overview

Chapter Contents

Serial Number Location 2

Intended Use 3

Equipment Modification 3

Machine Components 4

Regulatory Notices 5

- United States5
- Canada5

Operator Orientation 6

Operating Area 6

About This Manual 7

- Bulleted Lists 7
- Numbered Lists 7

California Proposition 65

 **WARNING** Diesel engine exhaust and some of its constituents are known to the State of California to cause cancer, birth defects, and other reproductive harm. www.P65warnings.ca.gov.

Serial Number Location

Record serial numbers and date of purchase in spaces provided. Serial number is located as shown.

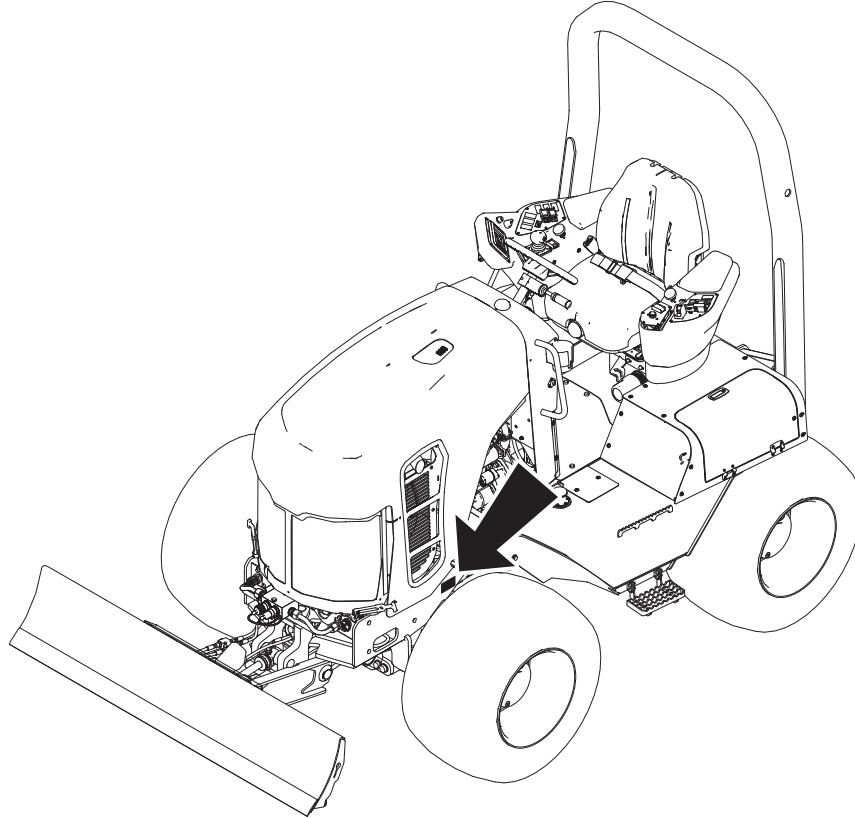

t63om001h21.eps

Item	
Date of manufacture	
Date of purchase	
Machine serial number	
Front attachment serial number	
Rear attachment serial number	

Intended Use

The RT70 is a riding trencher designed to install buried service lines of various sizes using a variety of Ditch Witch® attachments.

Attachment	Max. width/diameter	Max. depth
BH70 backhoe	18" (460mm) bucket	89" (2.3m)
CT70 trencher	12" (305mm)	61" (1.54m)
MT12 microtrencher	0.75-1.25" (19-32mm)	6-12.5" (165-318mm)
MT16 microtrencher	0.5-1.5" (12.7-38.1mm)	0-16" (0-406mm)
RC20 reel carrier	84" (2.1m) reel diameter	n/a
ST70 trencher	12" (305mm)	63.8" (1.62m)
VP70 plow	n/a	36" (915mm)

This machine is intended for operation only according to the instructions in this manual. Operate machine in ambient temperatures from 10° to 115°F (-12° to 46°C). Contact your Ditch Witch dealer for provisions required for operating in extreme temperatures. Use in any other way is considered contrary to the intended use.

This machine should be used with genuine Ditch Witch chain, teeth, and sprockets. It should be operated, serviced, and repaired only by professionals familiar with its particular characteristics and acquainted with the relevant safety procedures.

Equipment Modification

This equipment was designed and built in accordance with applicable standards and regulations. Modification of equipment could mean that it will no longer meet regulations and may not function properly or in accordance with the operating instructions. Modification of equipment should only be made by competent personnel possessing knowledge of applicable standards, regulations, equipment design functionality/requirements and any required specialized training.

NOTICE: The protection offered by the Rollover Protective Structure (ROPS) will be impaired if it has been subjected to any modification, structural damage, or has been involved in an overturn accident. The ROPS must be replaced after a roll-over.

Machine Components

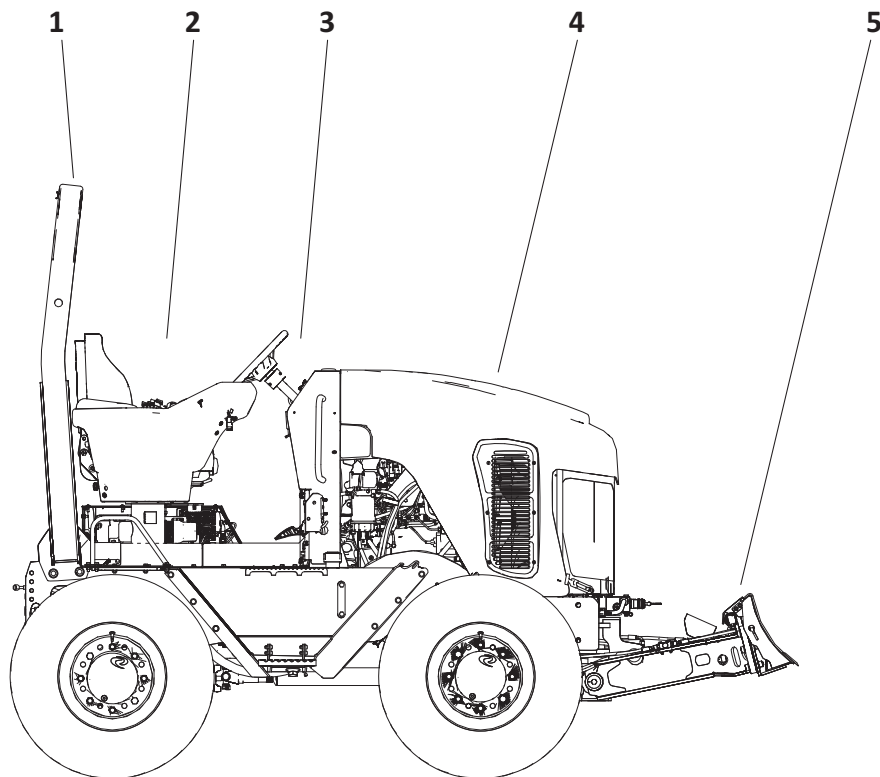

t630m002h21.eps

- | | |
|-----------------------------------------|-----------------------|
| 1. Rollover Protective Structure (ROPS) | 4. Engine compartment |
| 2. Operator station | 5. Backfill blade* |
| 3. Center console | |

*Optional

Regulatory Notices

Your equipment is designed and tested to meet regulatory codes and standards for electromagnetic compatibility. Digital electronics including wireless devices may be options on your equipment.

United States

Your equipment may contain the following: FCC ID: XPYLISAU200 or FCC ID: XMR201903EG25G

This device complies with Part 15 of the FCC Rules. Operation is subject to the following conditions: (1) this device may not cause harmful interference, and (2) this device must accept any interference received, including interference that may cause undesired operation. Changes or modifications not expressly approved by **The Charles Machine Works, Inc.** could void the user's authority to operate the equipment.

This equipment has been tested and found to comply with the limits for a Class B digital device, pursuant to Part 15 of the FCC rules. These limits are designed to provide reasonable protection against harmful interference in a residential installation. This equipment generates, uses and can radiate radio frequency energy and, if not installed and used in accordance with the instructions, may cause harmful interference to radio communications. However, there is no guarantee that interference will not occur in a particular installation. If this equipment does cause harmful interference to radio or television reception, which can be determined by turning the equipment off and on, the user is encouraged to try to correct the interference by one or more of the following measures:

- Reorient or relocate the receiving antenna.
- Increase the separation between the equipment and receiver.
- Connect equipment into an outlet on a circuit different from that to which the receiver is connected.
- Consult the dealer or an experienced radio/TV technician for help.

Canada

CAN ICES-2/NMB-2

This device complies with Industry Canada *license-exempt* RSS standard(s). Operation is subject to the following two conditions: (1) this device may not cause interference, and (2) this device must accept any interference, including interference that may cause undesired operation of the device.

Your equipment may contain the following IC: 8595A-LISAU200 or IC: 10224A-201903EG25G.

Le présent appareil est conforme aux CNR d'Industrie Canada applicables aux appareils radio exempts de licence. L'exploitation est autorisée aux deux conditions suivantes: (1) l'appareil ne doit pas produire de brouillage, et (2) l'appareil doit accepter tout brouillage radioélectrique subi, même si le brouillage est susceptible d'en compromettre le fonctionnement.

Votre équipement peut contenir les éléments suivants IC: 8595A-LISAU200 ou IC: 10224A-201903EG25G

Operator Orientation

IMPORTANT: Top view of machine is shown.

1. Front
2. Right side
3. Rear
4. Left side

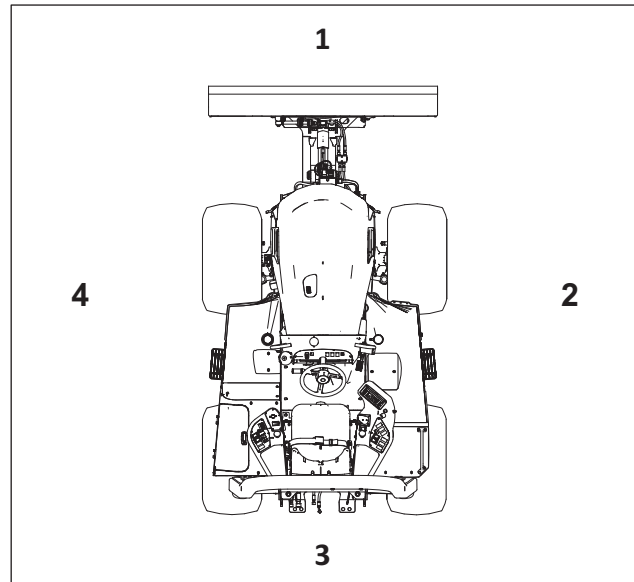

t63om003h21.eps

Operating Area

Operate only from designated seat(s).

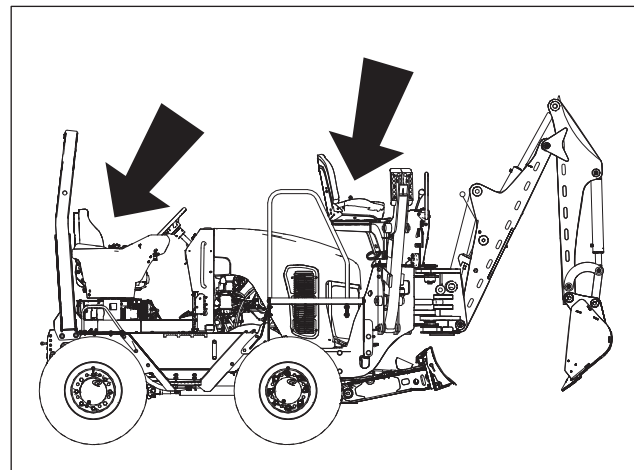

t63om004h21.eps

About This Manual

This manual contains information for the proper use of this machine. Cross references such as “See page 50” will direct you to detailed procedures.

Bulleted Lists

Bulleted lists provide helpful or important information or contain procedures that do not have to be performed in a specific order.

Numbered Lists

Numbered lists contain illustration callouts or list steps that must be performed in order.

Foreword

This manual is an important part of your equipment. It provides safety information and operation instructions to help maintain your Ditch Witch equipment.

Read this manual before using your equipment. Keep it with the equipment at all times for future reference. If you sell your equipment, be sure to give this manual to the new owner.

If you need a replacement copy, contact your Ditch Witch dealer. If you need assistance in locating a dealer, visit our website at www.ditchwitch.com or write to the following address:

The Charles Machine Works, Inc.
ATTN: Marketing Department
PO Box 66
Perry, OK 73077-0066
USA

The descriptions and specifications in this manual are subject to change without notice. The Charles Machine Works, Inc. reserves the right to improve equipment. Some product improvements may have taken place after this manual was published. For the latest information on Ditch Witch equipment, see your Ditch Witch dealer.

Thank you for buying and using Ditch Witch equipment.

**RT70
Operator's Manual**

equipped with tires or track

Issue number 2.0/OM-07/21

Part number 053-3307

Copyright 2021

by The Charles Machine Works, Inc.



and Ditch Witch are registered trademarks of The Charles Machine Works, Inc. Other trademarks and trade names are those of their respective owners.

This product and its use may be covered by one or more patents at <http://charlesmachine.works/patents>.

Contents

Overview	1
Machine serial number, information about the type of work this machine is designed to perform, basic machine components, and how to use this manual	
Foreword	9
Part number, revision level, and publication date of this manual, and factory contact information	
Safety	13
Machine safety alerts and emergency procedures	
Prepare	31
Procedures for preparing jobsite, preparing operator, and preparing equipment	
Controls	39
Machine controls, gauges, and indicators and how to use them	
Drive	83
Procedures for startup, cold start, driving, and shutdown	
Transport	89
Procedures for lifting, hauling, and retrieving	
Backhoe	97
Procedures for digging with backhoe	
Microtrench	103
Procedures for microtrenching	
Plow	113
Procedures for plowing	
Reel Carrier	119
Procedures for using reel carrier	

Trench	123
Procedures for trenching	
Systems and Equipment	129
Chain, teeth, sprockets, and optional equipment	
Complete the Job	141
Procedures for restoring the jobsite and rinsing and storing equipment	
Service	143
Service intervals and instructions for this machine including lubrication, replacement of wear items, and basic maintenance	
Specifications	195
Machine specifications including weights, measurements, power ratings, and fluid capacities	
Support	221
The warranty policy for this machine and procedures for obtaining warranty consideration and training	

Safety

Chapter Contents

	For additional precautions, see "Prepare" chapter.
-----------------------------------------------------------------------------------	----------------------------------------------------

- Safety Alert Classification 14**
- Guidelines 15**
- Emergency Procedures 16**
 - Electric Strike Description 16
 - If an Electric Line is Damaged 17
 - If a Gas Line is Damaged 17
 - If a Fiber Optic Cable is Damaged 17
 - If Machine Catches on Fire 17
- Machine Safety Alerts 19**

Safety Alert Classifications

These classifications and the icons defined on the following pages work together to alert you to situations which could be harmful to you, jobsite bystanders or your equipment. When you see these words and icons in the book or on the machine, carefully read and follow all instructions. **YOUR SAFETY IS AT STAKE.**

Watch for the three safety alert levels: **DANGER**, **WARNING** and **CAUTION**. Learn what each level means.

 **DANGER** indicates a hazardous situation that, if not avoided, will result in death or serious injury. This signal word is to be limited to the most extreme situations.

 **WARNING** indicates a hazardous situation that, if not avoided, could result in death or serious injury.



 **CAUTION** indicates a hazardous situation that, if not avoided, could result in minor or moderate injury.

Watch for two other words: **NOTICE** and **IMPORTANT**.

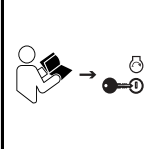

NOTICE indicates information considered important, but not hazard-related (e.g., messages relating to property damage).

IMPORTANT can help you do a better job or make your job easier in some way.

Guidelines



⚠ WARNING Misuse of machine can cause death or serious injury. Read and understand operator's manual and all other safety instructions before use. Know how to use all controls.



⚠ WARNING Raised component. Crushing can cause death or serious injury. Stay away. Use correct equipment and procedures.

Follow these guidelines before operating any jobsite equipment:

- Complete proper training.
- Read and understand operator's manual before using equipment.
- Wear personal protective equipment including long pants, hard hat, eye protection, hearing protection, and protective footwear.
- Do not wear jewelry or loose clothing.
- Mark proposed path with white paint and have underground utilities located before working. In the US or Canada, call 811 (US) or 888-258-0808 (US and Canada). Also contact any local utilities that do not participate in the One-Call service. In countries that do not have a One-Call service, contact all local utility companies to have underground utilities located.
- Classify jobsite based on its hazards and use correct tools and machinery, safety equipment, and work methods for jobsite.
- Mark jobsite clearly and keep spectators away.
- Review jobsite hazards, safety and emergency procedures, and individual responsibilities with all personnel before work begins. Safety videos are available from your Ditch Witch dealer or at www.ditchwitch.com/safe. Safety Data Sheets (SDS) are available at www.ditchwitch.com/support.
- Fully inspect equipment before operating. Repair or replace any worn or damaged parts. Replace missing or damaged safety shields and safety alert signs. Contact your Ditch Witch dealer for assistance.
- Follow instructions on all safety alert signs on machine.
- Use equipment carefully per the instructions in this manual. Stop operation and investigate anything that does not look or feel right.
- Do not operate machine where flammable gas may be present.
- Only operate equipment in well ventilated areas.
- Always tie down equipment and properly stow accessories, even if traveling short distances.

Emergency Procedures

- Contact your Ditch Witch dealer if you have any questions about operation, maintenance, or equipment use.
- Complete the equipment checklist located at www.ditchwitch.com/safe.

Emergency Procedures



⚠ WARNING Underground utilities. Contact can cause death or serious injury. Locate and verify underground utilities before digging or drilling.

Before operating any equipment, review emergency procedures and check that all safety precautions have been taken.

EMERGENCY SHUTDOWN: Shut off machine or press remote engine stop button (if equipped).

Electric Strike Description

When working near electric cables, remember the following:

- Electricity follows all paths to ground, not just path of least resistance.
- Pipes, hoses, and cables will conduct electricity back to all equipment.
- Low voltage current can injure or kill. Many work-related electrocutions result from contact with less than 440 volts.

Most electric strikes are not noticeable, but indications of a strike include:

- power outage
- smoke
- explosion
- popping noises
- arcing electricity

If any of these occur, assume an electric strike has occurred.

If an Electric Line is Damaged

If you suspect an electric line has been damaged, DO NOT MOVE. Take the following actions. The order and degree of action will depend on the situation.

- If you are **on the machine**, REMAIN ON MACHINE. Raise attachments and drive from immediate area.
- If you are **off the machine**,
 - DO NOT TOUCH ANY EQUIPMENT.
 - If you must leave the area, take small steps with feet close together to reduce the hazard of being shocked from one foot to the other.
- Warn people nearby that an electric strike has occurred. Instruct them to leave the area.
- Have someone contact electric company to shut off power.
- If you leave the area, do not return to jobsite or allow anyone into area until given permission by utility company.

If a Gas Line is Damaged

If you suspect a gas line has been damaged, take the following actions. The order and degree of action will depend on the situation.

- Immediately shut off engine(s), if this can be done safely and quickly.
- Remove any ignition source(s), if this can be done safely and quickly.
- Warn others that a gas line has been cut and that they should leave the area.
- After warning others to leave the area, leave jobsite as quickly as possible.
- Immediately call your local emergency phone number and utility company.
- If jobsite is along street, stop traffic from driving near jobsite.
- Do not return to jobsite until given permission by emergency personnel and utility company.

If a Fiber Optic Cable is Damaged

Do not look into cut ends of fiber optic or unidentified cable. Vision damage can occur. Contact utility company.

If Machine Catches on Fire

Perform emergency shutdown procedure and then take the following actions. The order and degree of action will depend on the situation.

- Immediately move battery disconnect switch (if equipped and accessible) to disconnect position.
- If fire is small and fire extinguisher is available, attempt to extinguish fire.
- If fire cannot be extinguished, leave area as quickly as possible and contact emergency personnel.

RT70 Safety Alerts

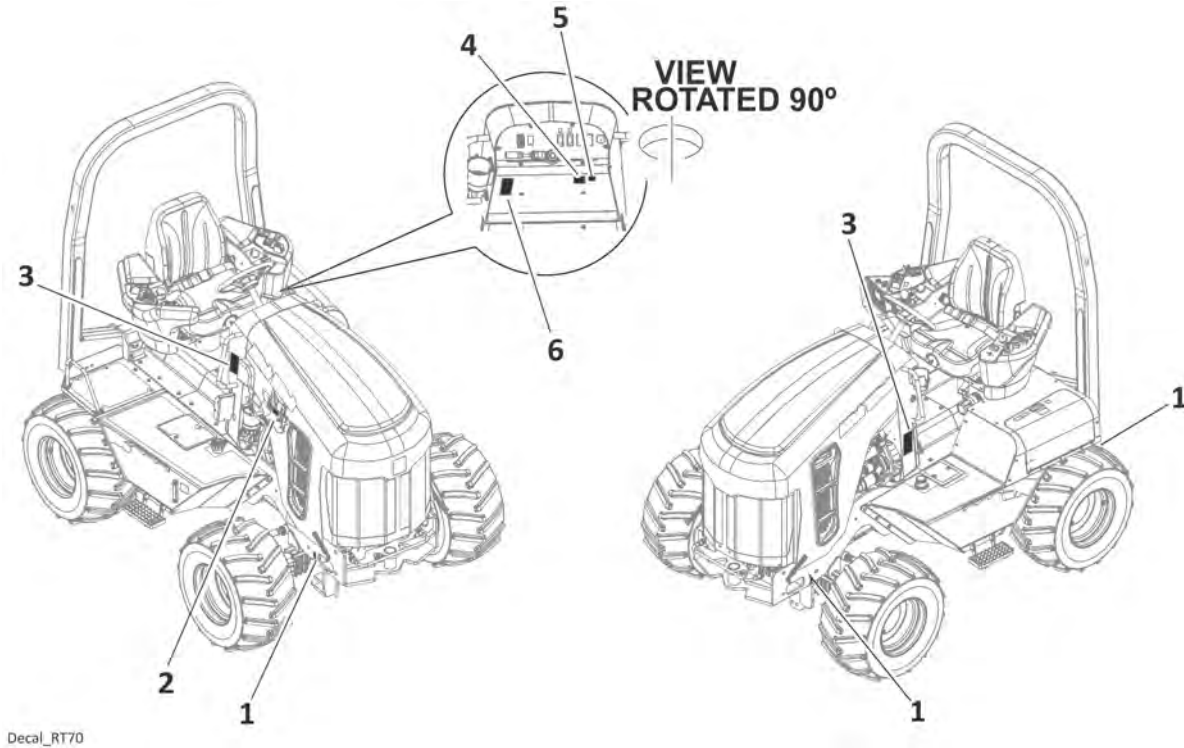

1.



Tiedown location. See Transport chapter for more information.

2.



! WARNING Pre-heater. Fire or explosion can cause death or serious injury. Never use starter fluid.

3.



! WARNING Moving machine. Fall can cause death or serious injury. Only operator is allowed on machine. No riders.

4.



! WARNING Underground utilities. Contact can cause death or serious injury. Locate and verify underground utilities before digging or drilling.

5.

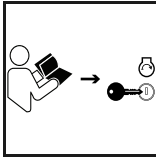

⚠ WARNING Misuse of machine can cause death or serious injury. Read and understand operator's manual and all other safety instructions before use. Know how to use all controls.

6.

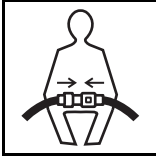

⚠ WARNING Rollover. Crushing can cause death or serious injury. Wear seat belt.

Attachment Safety Alerts

BH70

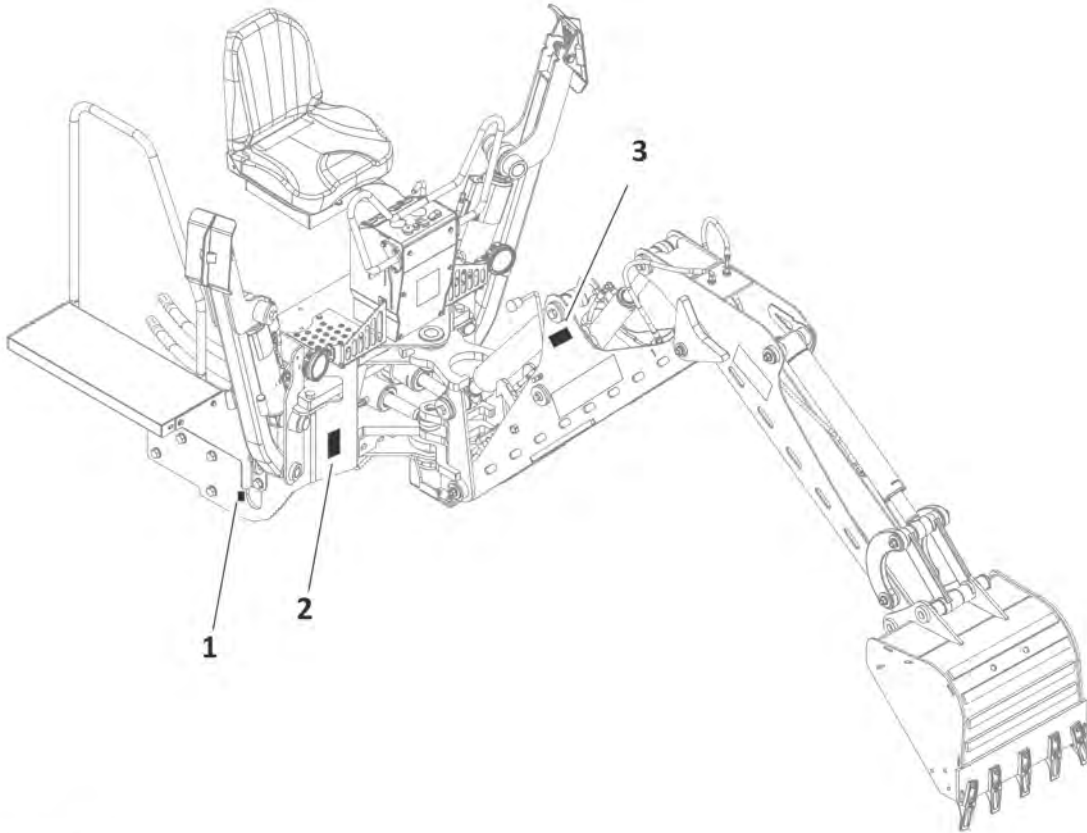

Decal_BH70

1.



Tiedown location. See Transport chapter for more information.

2.

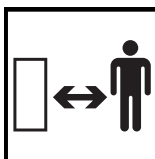

! WARNING

Moving parts. Contact can cause serious injury. Stay away.

3.

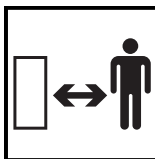

! WARNING

Lifted load. Crushing can cause death or serious injury. Stay away from lifted load and its range of movement.

CT70

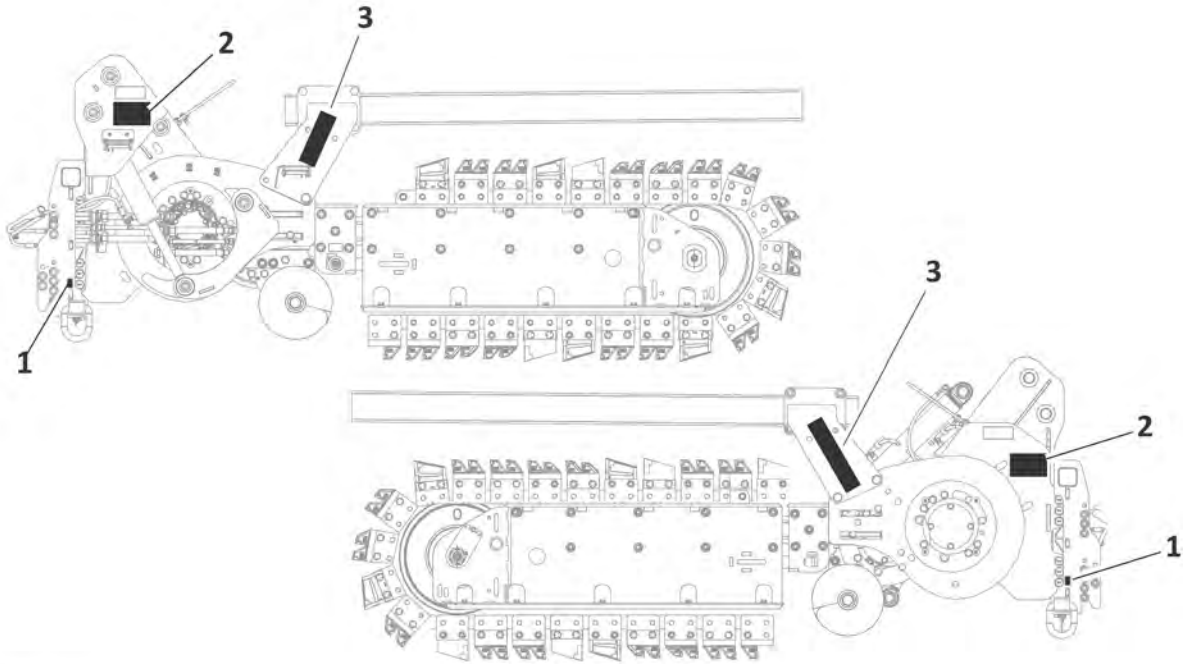

Decal_CT70

1.



Tiedown location. See Transport chapter for more information.

2.

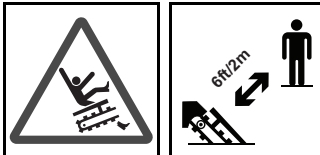

! DANGER Moving digging teeth. Contact will cause death or serious injury. Stay at least 6ft (2m) away.

3.

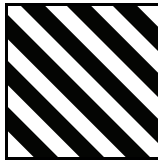

DANGER stripe decal. See Parts Manual for replacement part numbers.

ST70

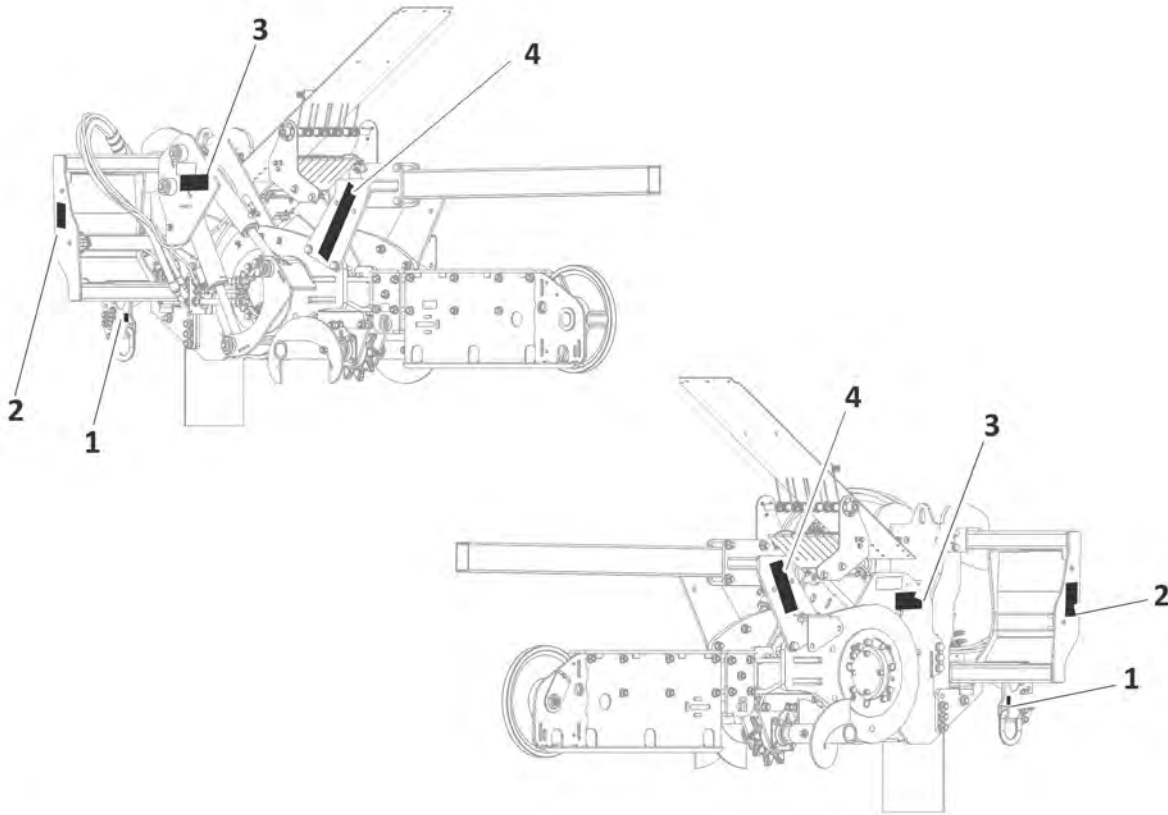

Decal_ST70

1. Tiedown location. See Transport chapter for more information.



2. **WARNING** Moving parts. Contact can cause serious injury. Stay away.

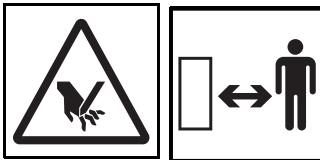

3. **DANGER** Moving digging teeth. Contact will cause death or serious injury. Stay at least 6ft (2m) away.

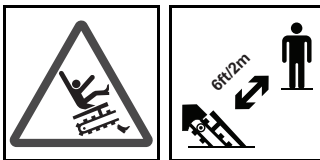

4. DANGER stripe decal. See Parts Manual for replacement part numbers.

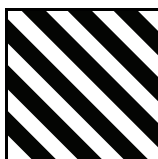

VP70

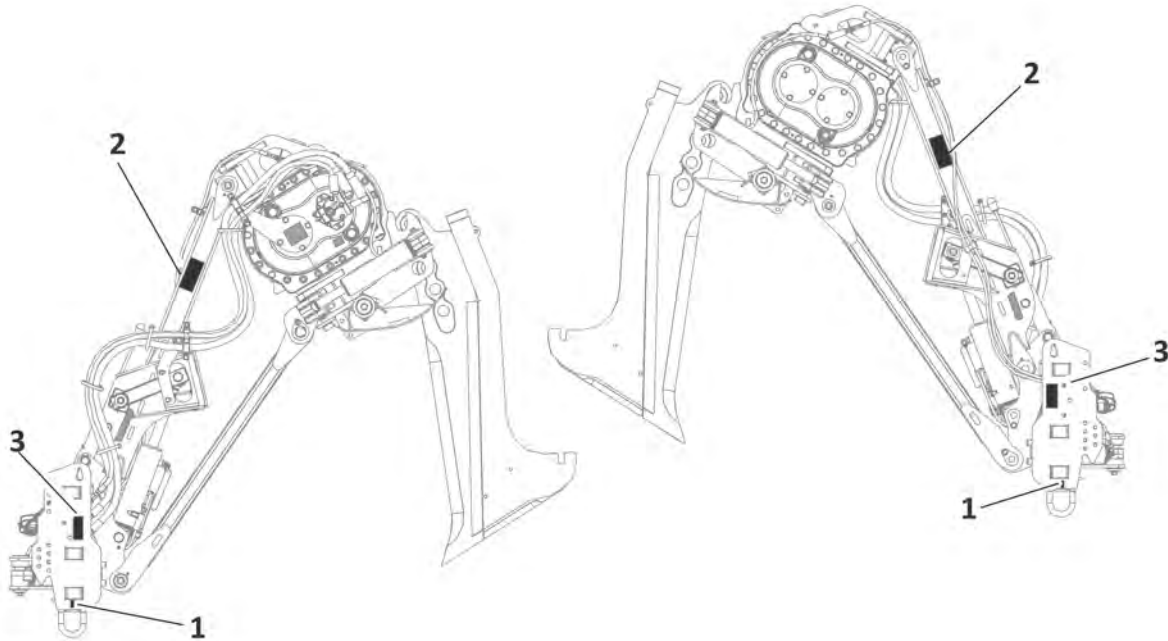

Decal_VP70

1.



Tiedown location. See Transport chapter for more information.

2.

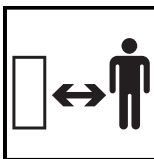

! WARNING Lifted load. Crushing can cause death or serious injury. Stay away from lifted load and its range of movement.

3.

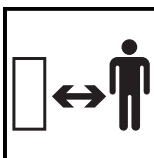

! WARNING Moving parts. Contact can cause serious injury. Stay away.

MT12

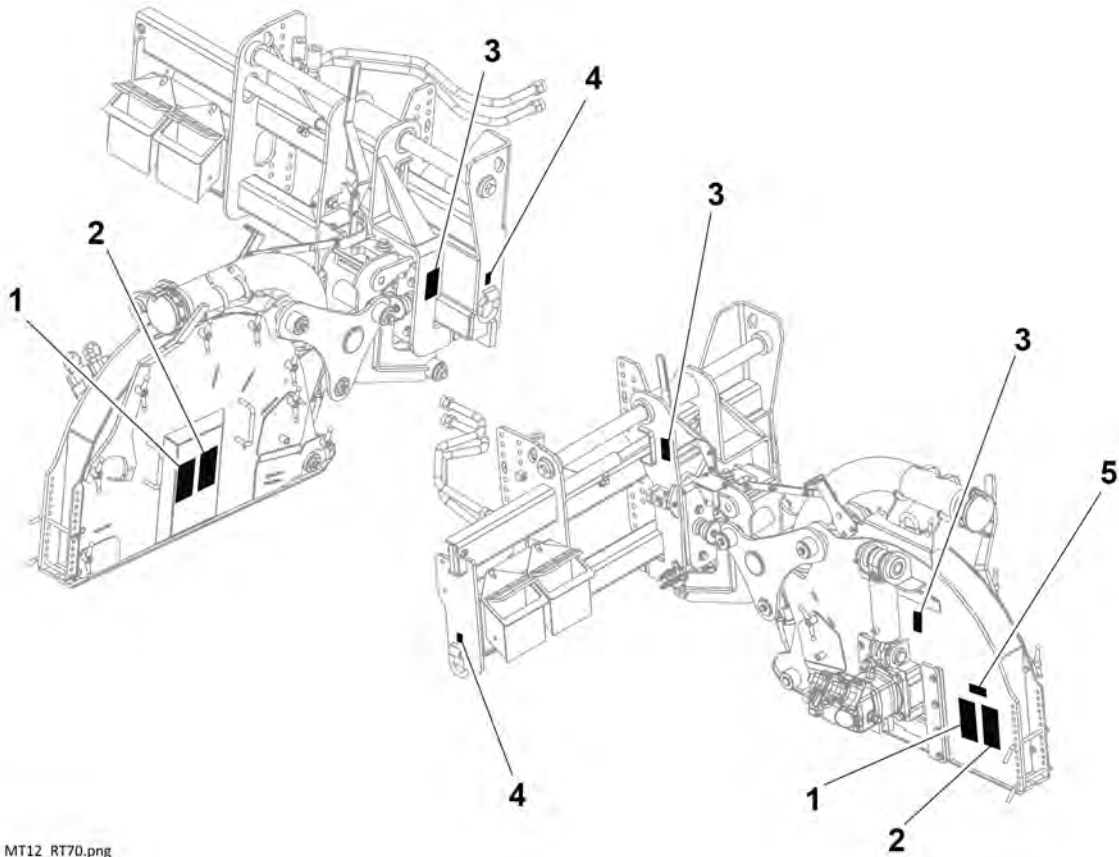

1.



CAUTION Thrown objects. Impact can cause injury. Wear hard hat and safety glasses.

2.

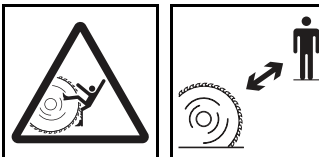

DANGER Moving digging teeth. Contact will cause death or serious injury. Stay at least 6ft (1.8m) away.

3.

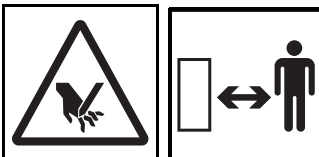

WARNING Moving parts. Contact can cause serious injury. Stay away.

4.



Tiedown location. See Transport chapter for more information.

5.



! WARNING

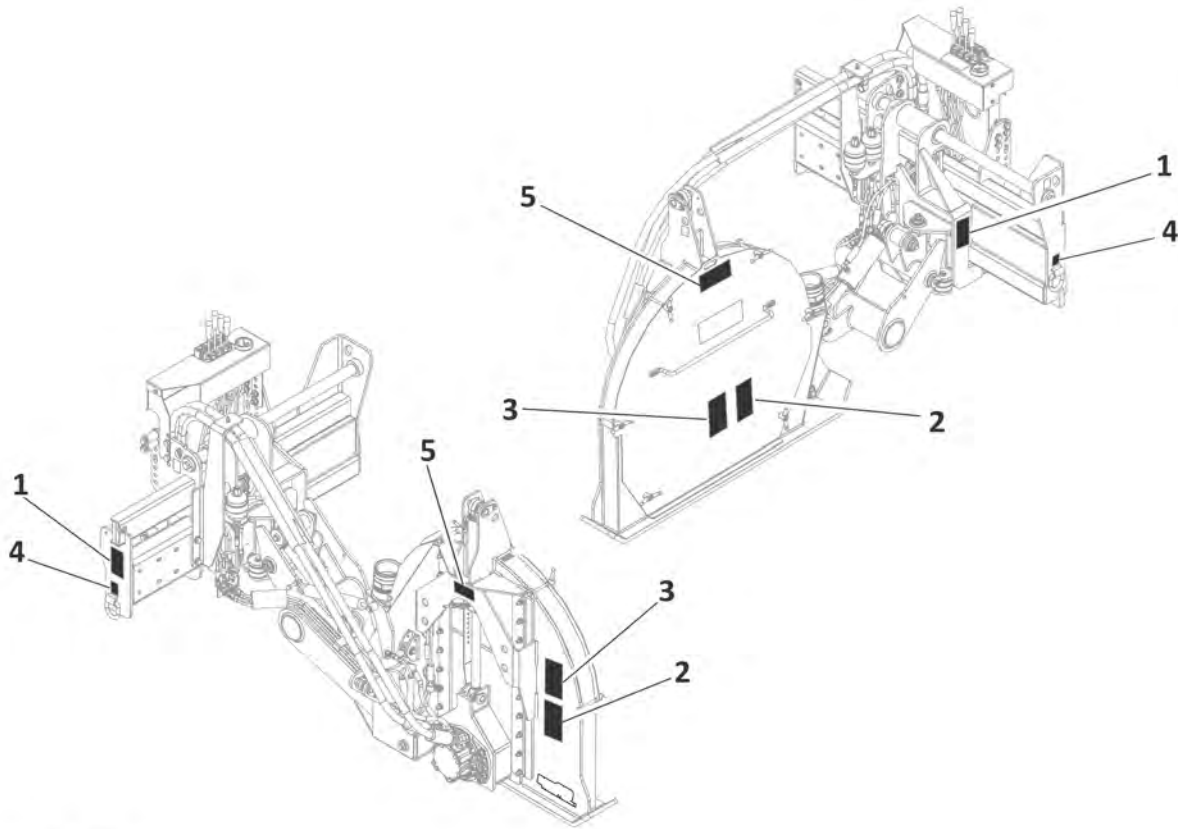

Silica dust. Exposure can cause lung disease. Use breathing protection.

MT16

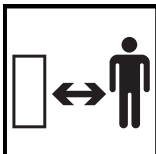

Decal_MT16_RT70.png

1.   **⚠ WARNING** Moving parts. Contact can cause serious injury. Stay away.

2.   **⚠ CAUTION** Thrown objects. Impact can cause injury. Wear hard hat and safety glasses.

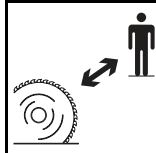
3.   **⚠ DANGER** Moving digging teeth. Contact will cause death or serious injury. Stay at least 6ft (1.8m) away.

4.



Tiedown location. See Transport chapter for more information.

5.

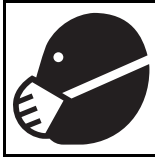

! WARNING

Silica dust. Exposure can cause lung disease. Use breathing protection.

RC20

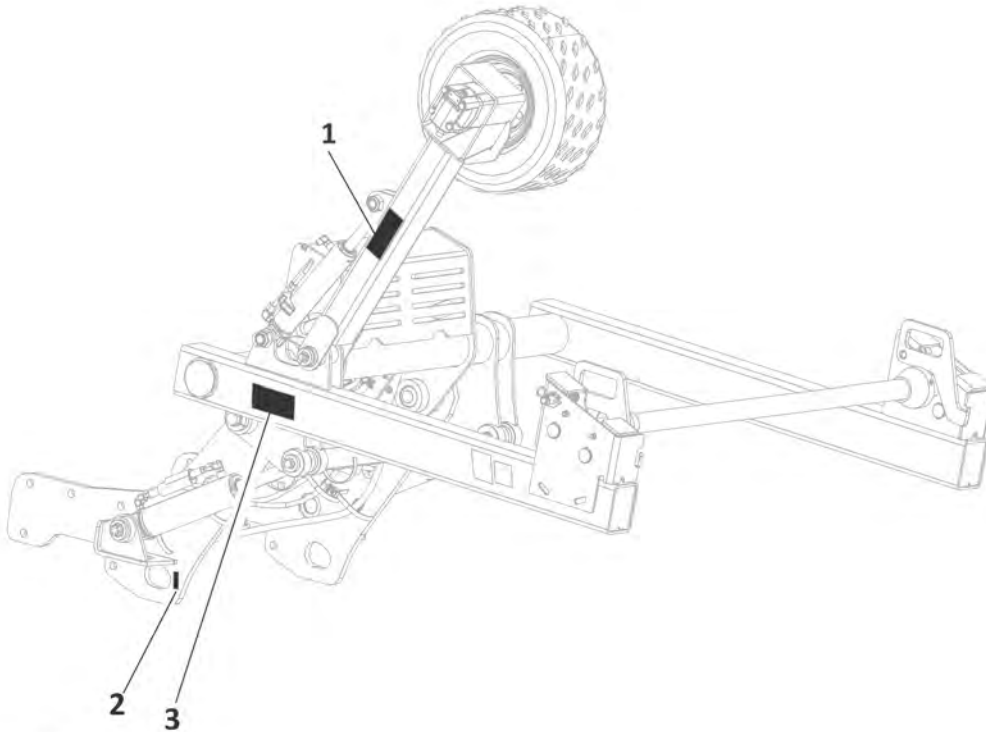

Decal_RC70

1.

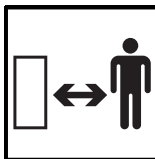

WARNING

Moving parts. Contact can cause serious injury. Stay away.

2.



Tiedown location. See Transport chapter for more information.

3.

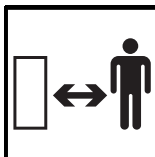

WARNING

Lifted load. Crushing can cause death or serious injury. Stay away from lifted load and its range of movement.

Prepare

Chapter Contents

	For additional precautions, see "Safety" chapter.
-----------------------------------------------------------------------------------	---------------------------------------------------

Prepare Jobsite 32

- Review Job Plan 32
- Select Start and End Points 32
- Identify Hazards 33
- Locate Utilities 33
- Classify Jobsite 34
- Arrange for Traffic Control 35

Prepare Operator 36

Prepare Equipment 37

- Check Supplies 37
- Check Equipment 37
- Assemble Accessories 38

Prepare Jobsite



WARNING

Underground utilities. Contact can cause death or serious injury. Locate and verify underground utilities before digging or drilling.

To help avoid injury:

- Expose lines by careful hand digging or soft excavation before operating equipment. Use appropriate equipment and procedures for exposing utility lines.
- Classify jobsite and follow precautions based on classification.
- Follow local regulations for digging near utilities.

A successful job begins before working. The first step in planning is reviewing information already available about the job and jobsite.

Review Job Plan

Review blueprints or other plans. Check for information about existing or planned structures, elevations, or proposed work that may be taking place at the same time.

Select Start and End Points

Select one end to use as a starting point. Consider the following when selecting a starting point:

Slope

Equipment should be parked on a level site. Consider how slope will affect setup and operation. Assess the risks on each slope to determine if factors affecting risks create an unsafe condition for working. See “Slope Guidelines” on page 74.

Space

Check that starting and ending points allow enough space for working.

Comfort

Consider shade, wind, fumes, and other site features.

Identify Hazards

Inspect jobsite before transporting equipment. Check for the following:

- overall grade or slope
- changes in elevation such as hills or open trenches
- obstacles such as buildings, railroad crossings, or streams
- signs of utilities
 - "buried utility" notices
 - gas or water meters
 - drop boxes
 - manhole covers
 - utility facilities without overhead lines
 - junction boxes
 - light poles
 - sunken ground
- traffic
- access
- soil type and condition
- loose material such as fencing or cable

Locate Utilities

Notify One-Call Services

Mark proposed path with white paint and have underground utilities located before working.

- In the US or Canada, call 811 (US) or 888-258-0808 (US and Canada). Also contact any local utilities that do not participate in the One-Call service.
- In countries that do not have a One-Call service, contact all local utility companies to have underground utilities located.

Verify Underground Utilities

Have an experienced locating equipment operator sweep area within 20' (6 m) to each side of proposed excavation to verify previously marked line and cable locations. Mark location of all buried utilities and obstructions.

Locate Overhead Lines

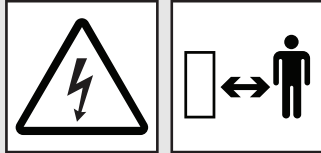

⚠ DANGER Overhead electrical lines. Contact will cause death or serious injury. Know location of lines. Stay away.

Note location and height of all overhead lines in jobsite and ensure that equipment maintains proper distance from live lines.

Classify Jobsite

Select a Classification

Jobsites are classified according to underground hazards present, not by line being installed. Jobsite may have more than one classification.

If working . . .	then classify jobsite as . . .
within 10' (3m) of a buried electric line	electric
within 10' (3m) of a natural gas line	natural gas
in concrete, sand, or granite which is capable of producing crystalline silica dust	crystalline silica dust
within 10' (3m) of any other hazard	other

Classify jobsite as electric if jobsite is in question or if the possibility of unmarked electric utilities exists.

Apply Precautions



⚠ WARNING Underground utilities. Contact can cause death or serious injury. Locate and verify underground utilities before digging or drilling.

Once classified, precautions appropriate for jobsite must be taken. Follow US Department of Labor regulations on excavating and trenching (Part 1926, Subpart P) and other similar regulations.

Electric Jobsite Precautions

Use one or both of these methods:

- Expose line by careful hand digging or soft excavation.
- Have service shut down while work is in progress. Have electric company test lines before returning them to service.

Natural Gas Jobsite Precautions

Position equipment upwind from gas lines and use one or both of these methods:

- Expose line by careful hand digging or soft excavation.
- Have service shut down while work is in progress. Have gas company test lines before returning them to service.

Crystalline Dust Jobsite Precautions

⚠ WARNING Silica dust. Exposure can cause lung disease or cancer. Use breathing protection.

Crystalline silica dust is a naturally occurring substance found in soil, sand, concrete, granite, and quartz.

To reduce exposure when cutting, drilling, or working these materials:

- Use water spray or other means to control dust.
- Refer to US Occupational Safety and Health Administration (OSHA) guidelines or other applicable regulating guidelines for appropriate breathing protection or dust control methods.

Other Jobsite Precautions

You may need to use different methods to safely avoid other underground hazards. Talk with those knowledgeable about hazards present at each site to determine which precautions should be taken or if job should be attempted.

Clear objects such as landscaping fabric, cable, and wire from the work area. These objects may be underground or partially buried.

Arrange for Traffic Control

Vehicle and pedestrian traffic must be a safe distance from equipment. Evaluate jobsite and allow an appropriate buffer zone around equipment. If working near a road or other traffic area, contact local authorities about safety procedures and regulations.

Prepare Operator

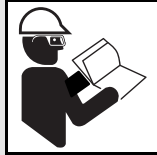

⚠ WARNING

Jobsite hazards. Exposure can cause death or serious injury. Use correct equipment and work methods. Use and maintain appropriate safety equipment.

To help avoid injury:

- Wear personal protective equipment including hard hat, safety eye wear, foot protection, hearing protection, and gloves (except when near rotating equipment).
- Remove jewelry.
- Wear close-fitting, high visibility clothing.
- Have other personal protective equipment, such as insulated boots and gloves, breathing protection, and face shield, etc. available for use depending on jobsite hazards or requirements.

Follow these guidelines before operating any jobsite equipment:

- Complete proper training and read operator's manual before using equipment.
- Plan for emergency services. Have the telephone numbers for local emergency and medical facilities on hand. Check that you will have access to a telephone.
- Review jobsite hazards, safety and emergency procedures, and individual responsibilities with all personnel before work begins. Safety videos are available from your Ditch Witch® dealer or at www.ditchwitch.com/safe. Safety Data Sheets (SDS) are available at www.ditchwitch.com/support.
- Use equipment carefully. Stop operation and investigate anything that does not look or feel right.

Prepare Equipment

Check Supplies

- fuel
- keys
- marking flags or paint
- notepad and pencil
- spare fuses
- lubricants
- extra batteries for accessories and equipment

Check Equipment

Fluid Levels

- fuel
- engine oil
- hydraulic fluid
- engine coolant

Condition and Function

- all controls

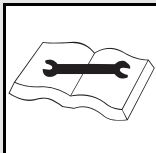

⚠ WARNING Improper control function. Use can cause death or serious injury. If control does not work as described in instructions, stop machine and have it serviced.

- battery
- hoses and valves
- pumps and motors
- tires or tracks
- signs, guards, and shields
- filters (air, oil, hydraulic)
- belts

Assemble Accessories

Fire Extinguisher

NOTICE: Do not drill into ROPS to mount extinguisher.

Clamp a fire extinguisher near the power unit but away from possible points of ignition where shown. The fire extinguisher should always be classified for both oil and electric fires. It should meet legal and regulatory requirements.

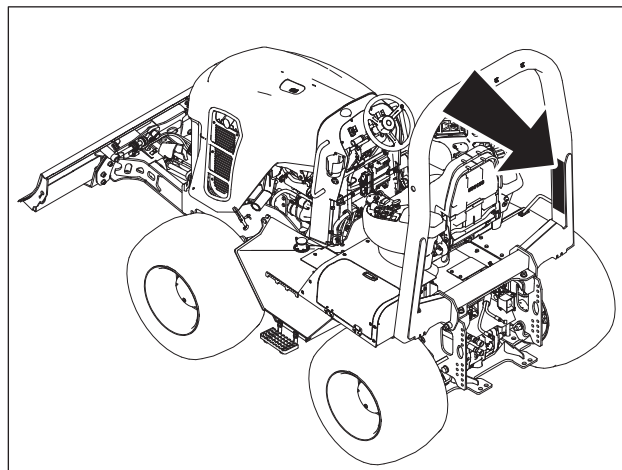

t63om005h21.eps

Counterweights

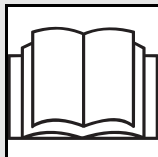
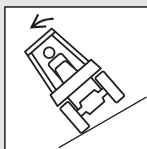

⚠ WARNING Tipover. Crushing can cause death or serious injury. Follow procedure in operator's manual. Drive cautiously.

To help avoid injury: Use attachments or counterweights to make front and rear loads balance when all attachments are raised. Contact your Ditch Witch dealer about counterweighting for your equipment.

Install counterweights as needed for attachment. See "Counterweights" on page 125.

Controls

Chapter Contents

Battery Disconnect	40
Console, Backhoe	41
Console, Center	45
Console, Left	48
Console, Right	52
Display	59
• Gauges and Indicators	59
• Soft Keys	64
• Main Menu	65
• Display Pop-Up Messages	67
Display, Trench Depth Meter	68
• Trench Indicators	68
• Soft Keys	69
• Depth Meter Screen	70
• Soft Keys	73
Microtrencher	75
Plow	77
Seat	78
• Standard	78
• Suspension	80

Battery Disconnect

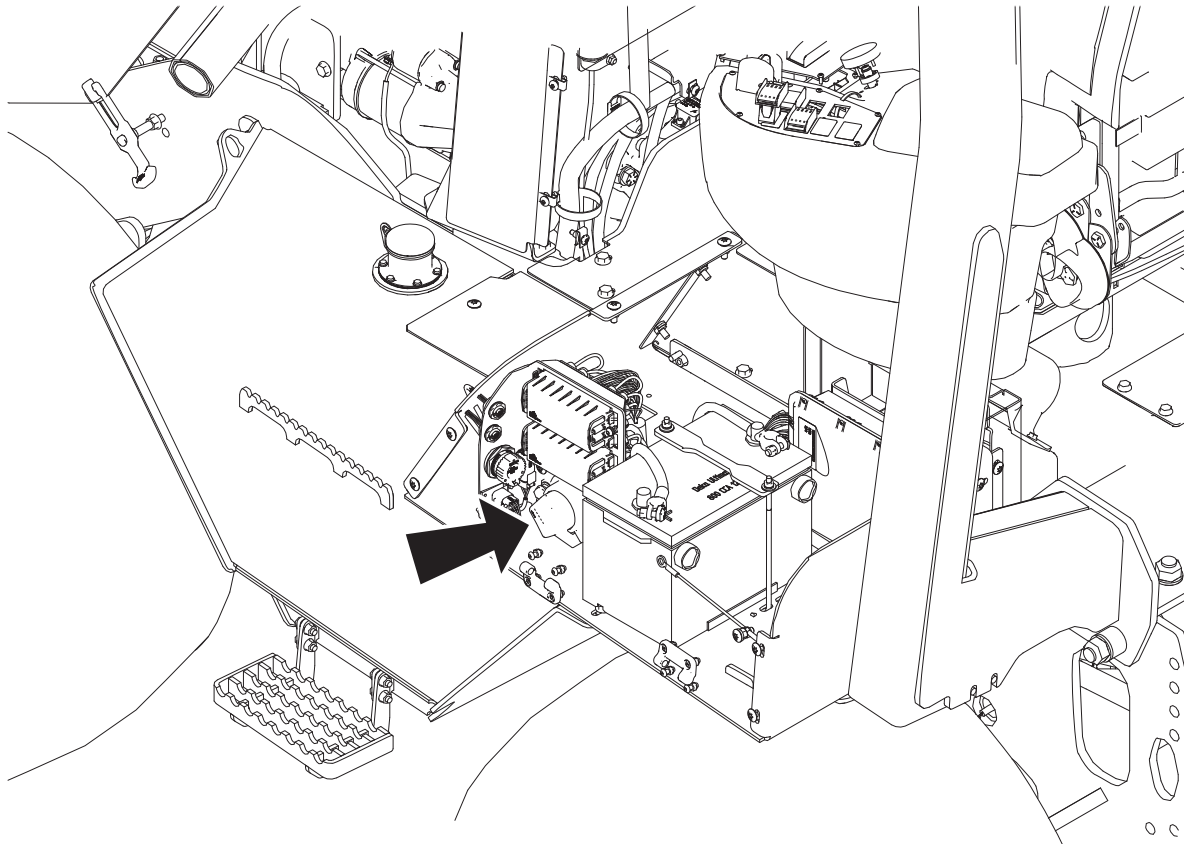

t63om006h21.eps

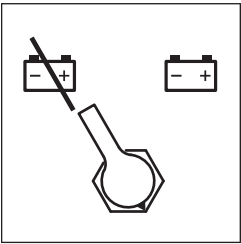
Item	Description	IMPORTANT
<p data-bbox="203 1251 516 1278">Battery disconnect switch</p>  <p data-bbox="261 1528 370 1545">c00ic654w.eps</p>	<p data-bbox="586 1251 862 1278">To connect, move right.</p> <p data-bbox="586 1318 878 1346">To disconnect, move left.</p>	<p data-bbox="967 1251 1068 1278">NOTICE:</p> <ul data-bbox="967 1318 1414 1503" style="list-style-type: none"> <li data-bbox="967 1318 1414 1381">• Do not disconnect with engine running. <li data-bbox="967 1402 1414 1503">• To avoid equipment damage, wait two minutes after turning engine off before disconnecting battery. <p data-bbox="967 1543 1414 1642">To lock out battery disconnect switch, insert padlock through hole above handle.</p>

Console, Backhoe

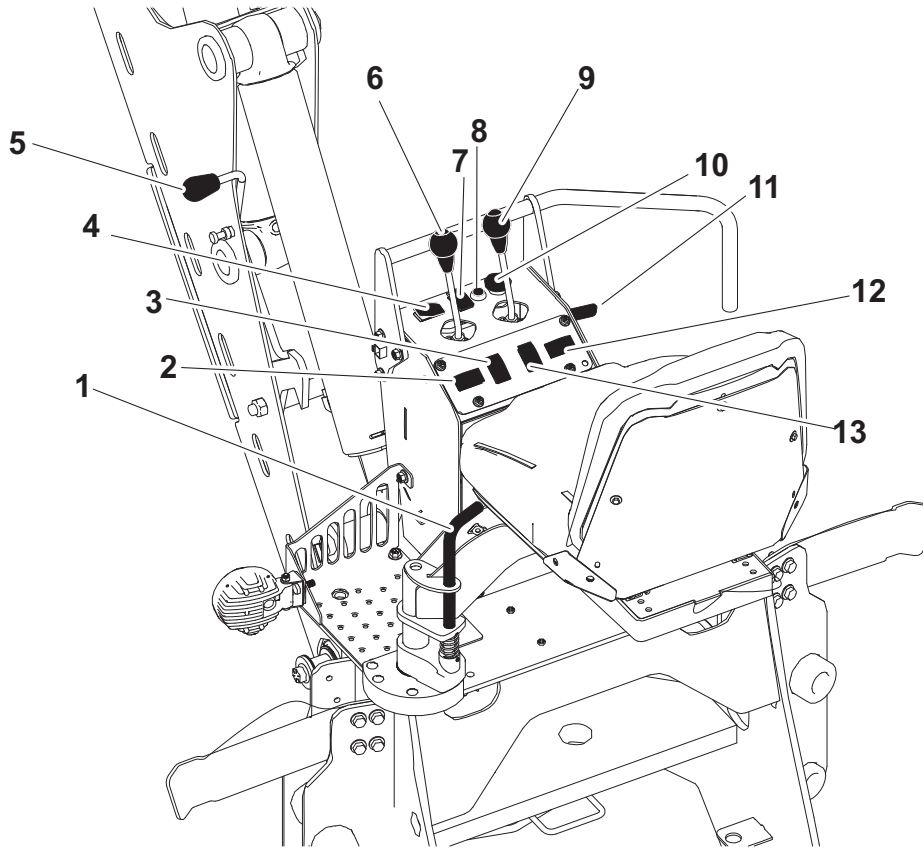

t63om007h21.eps

IMPORTANT: Operator must be in backhoe seat for BH70 controls to function.

- | | |
|-----------------------------------|---------------------------------|
| 1. Seat lock pin | 8. Remote start switch |
| 2. Left stabilizer control | 9. Bucket/Dipper control |
| 3. Remote backfill blade control* | 10. Remote engine stop button |
| 4. Work light switch* | 11. Swing lock |
| 5. Stow lock control | 12. Right stabilizer control |
| 6. Boom/Swing control | 13. Remote ground drive control |
| 7. Remote throttle control | |
- *If equipped

Item	Description	IMPORTANT
1. Seat lock pin	To change seat position, lift. To secure seat position, lower.	

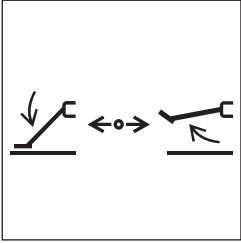
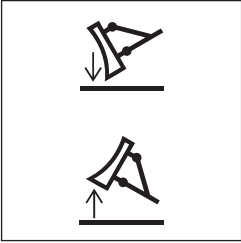
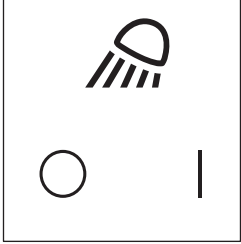
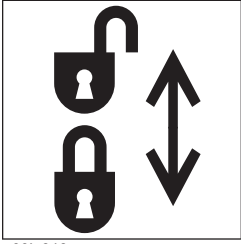
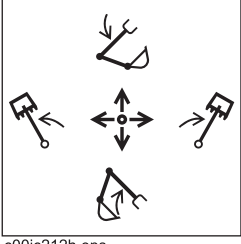
Item	Description	IMPORTANT
<p>2. Left stabilizer control</p>  <p>c00ic211h.eps</p>	<p>To lower, press left.</p> <p>To raise, press right.</p>	
<p>3. Remote backfill blade control</p>  <p>c00ic210h.eps</p>	<p>To lower, press top.</p> <p>To raise, press bottom.</p>	
<p>4. Work light switch</p>  <p>c00ic086c.eps</p>	<p>To turn on, press right.</p> <p>To turn off, press left.</p>	
<p>5. Stow lock control</p>  <p>c00ic646w.eps</p>	<p>To lock, push down and into hook.</p> <p>To release, pull up and into hook.</p>	<p>NOTICE: Always use stow lock during transport.</p>
<p>6. Boom/Swing control</p>  <p>c00ic212h.eps</p>	<p>To swing left, move left.</p> <p>To swing right, move right.</p> <p>To raise, pull.</p> <p>To lower, push.</p>	<p>NOTICE: Do not operate with backhoe in the stowed (upright) position.</p> <p>Control can perform more than one action at a time. By "feathering" the control, operator can combine backhoe operations.</p>

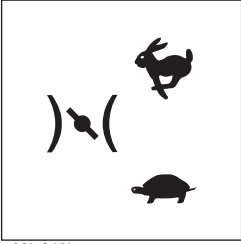
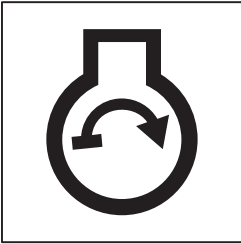
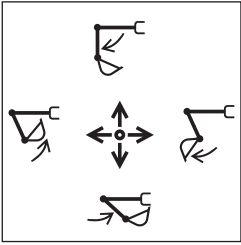
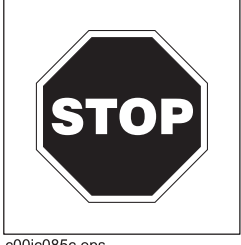
Item	Description	IMPORTANT
<p>7. Remote throttle control</p>  <p>c00ic243h.eps</p>	<p>To increase engine speed, press top.</p> <p>To decrease, press bottom.</p>	
<p>8. Remote start switch</p>  <p>c00ic056t.eps</p>	<p>To start engine, press.</p>	<p>IMPORTANT: Ignition switch on right console must be on to start engine remotely.</p>
<p>9. Bucket/Dipper control</p>  <p>c00ic213h.eps</p>	<p>To open bucket, move right.</p> <p>To close, move left.</p> <p>To move dipper in, pull back.</p> <p>To move out, push forward.</p>	<p>Control can perform more than one action at a time. By "feathering" the control, operator can combine backhoe operations.</p>
<p>10. Remote engine stop button</p>  <p>c00ic085c.eps</p>	<p>To stop engine, press.</p>	<p>To shut off machine normally, use ignition switch.</p> <p>Ignition will not start if remote engine stop is engaged.</p>

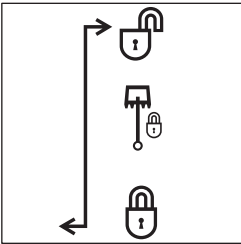
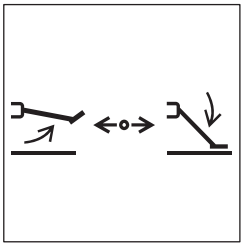
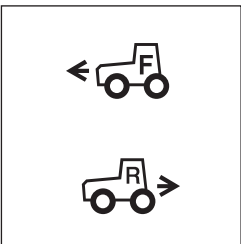
Item	Description	IMPORTANT
<p>11. Swing lock</p>  <p>The diagram shows a vertical line with three padlock icons. The top padlock is closed. An arrow points from the top padlock to a handle icon in the middle, which is also closed. A second arrow points from the handle icon to a bottom padlock icon, which is open. Below the diagram is the file name 'c00ic089c.eps'.</p>	<p>To lock:</p> <ol style="list-style-type: none"> 1. Raise boom fully. 2. Pull swing lock handle. 3. Insert swing lock pin. <p>To release:</p> <ol style="list-style-type: none"> 1. Raise boom slightly. 2. Push swing lock handle to release lock. 	<p>See "Stow lock control" on page 42.</p> <p>NOTICE: Always use swing lock during transport.</p>
<p>12. Right stabilizer control</p>  <p>The diagram shows a horizontal line with two stabilizer icons. The left icon has an arrow pointing up and to the right. The right icon has an arrow pointing down and to the left. A double-headed arrow is between the two icons. Below the diagram is the file name 'c00ic088c.eps'.</p>	<p>To lower, press right.</p> <p>To raise, press left.</p>	
<p>13. Remote ground drive control</p>  <p>The diagram shows two tractor icons. The top icon is labeled 'F' and has an arrow pointing left. The bottom icon is labeled 'R' and has an arrow pointing right. Below the diagram is the file name 'c00ic216h.eps'.</p>	<p>To move forward, press top.</p> <p>To move in reverse, press bottom.</p>	<p>NOTICE:</p> <ul style="list-style-type: none"> • This control is disabled if tractor seat is occupied. • Gearbox must be in low and ground drive direction control must be in neutral for remote ground drive to function. • Ensure that backfill blade (if equipped) and stabilizers are raised and parking brake is released before operating this control. • Do not move more than 30' (10m) at a time.

Console, Center

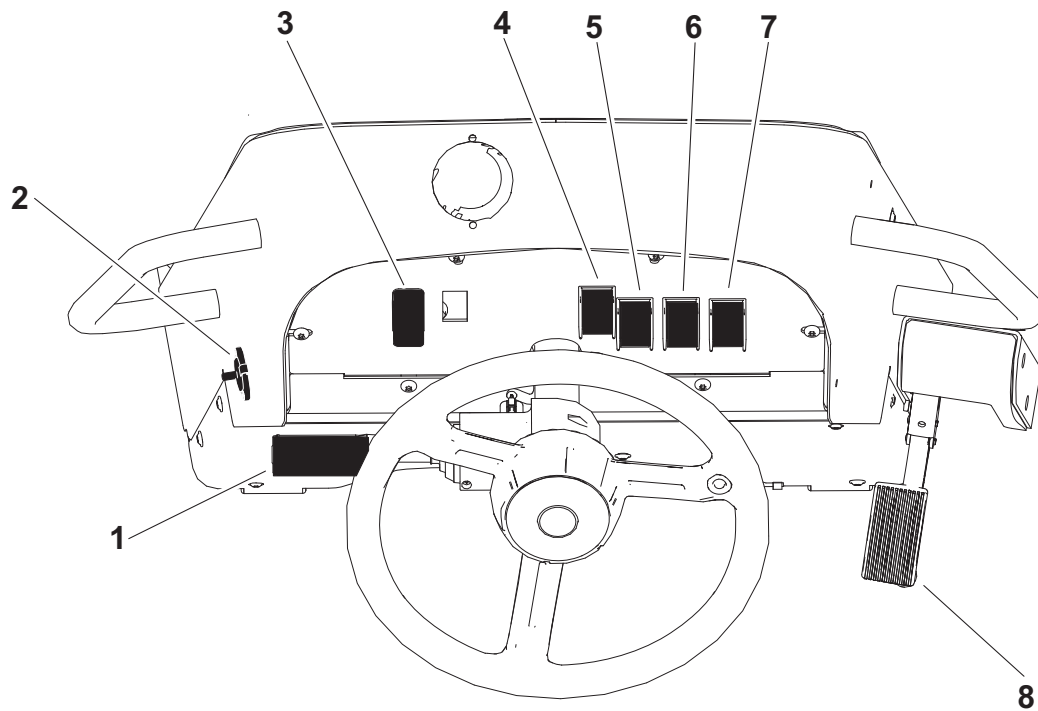



t63om008h21.eps

- | | |
|-----------------------------------------|------------------------------|
| 1. Ground drive direction/speed control | 5. Hazard light switch * |
| 2. Auxiliary outlet | 6. Front work light switch * |
| 3. USB | 7. Blank |
| 4. Work light switch * | 8. Ground drive foot control |

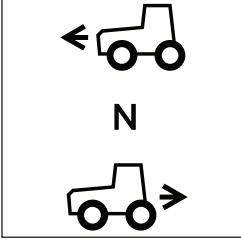
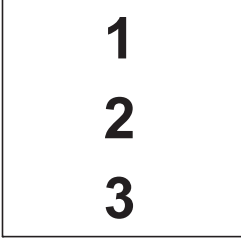
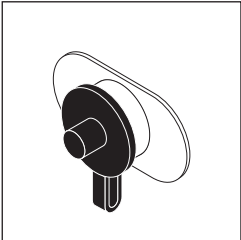
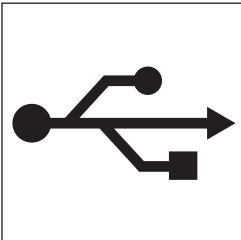
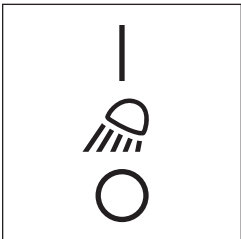
* If equipped

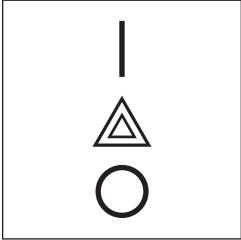
Item	Description	IMPORTANT
<p>1. Ground drive direction/ speed control</p>  <p><small>c00ic161w.eps</small></p>  <p><small>c00ic151w.eps</small></p>	<p>To move tractor forward, move lever to the upper position.</p> <p>To put tractor in neutral, move lever to the center position.</p> <p>To move tractor in reverse, move lever to the lower position.</p> <p>To select High (3), Medium (2) or Low (1), rotate knob to appropriate position.</p>	<p>Must be in forward or reverse position for ground drive foot control to function. See "Ground drive foot control" on page 47.</p> <p>Display indicates forward, neutral, or reverse selection.</p> <p>Screen icon displays High, Medium or Low selection.</p>
<p>2. Auxiliary outlet</p>  <p><small>c00ic179h.eps</small></p>	<p>Provides power for other equipment.</p>	<p>DC12V, 10A (120W)</p>
<p>3. USB</p>  <p><small>c00ic250w.eps</small></p>	<p>Provides power for mobile devices.</p>	<p>DC5V, 1A (5W)</p> <p>DC5V, 2.1A (10.5W)</p>
<p>4. Work light switch</p>  <p><small>c00ic601w.eps</small></p>	<p>To turn on, press top.</p> <p>To turn off, press bottom.</p>	

Item	Description	IMPORTANT
<p>5. Hazard light switch</p>  <p><small>c00ic600w.eps</small></p>	<p>To turn on, press top.</p> <p>To turn off, press bottom.</p>	
<p>6. Front work light switch</p>  <p><small>c00ic601w.eps</small></p>	<p>To turn on, press top.</p> <p>To turn off, press bottom.</p>	
<p>7. Blank</p>		
<p>8. Ground drive foot control</p>	<p>To move machine, press.</p> <p>To increase speed, press.</p> <p>To reduce speed, release pedal slightly.</p>	<p>To function, ground drive direction control must be in forward or reverse. See "Ground drive direction/speed control" on page 46.</p> <p>Pedal should automatically return to neutral when released.</p>

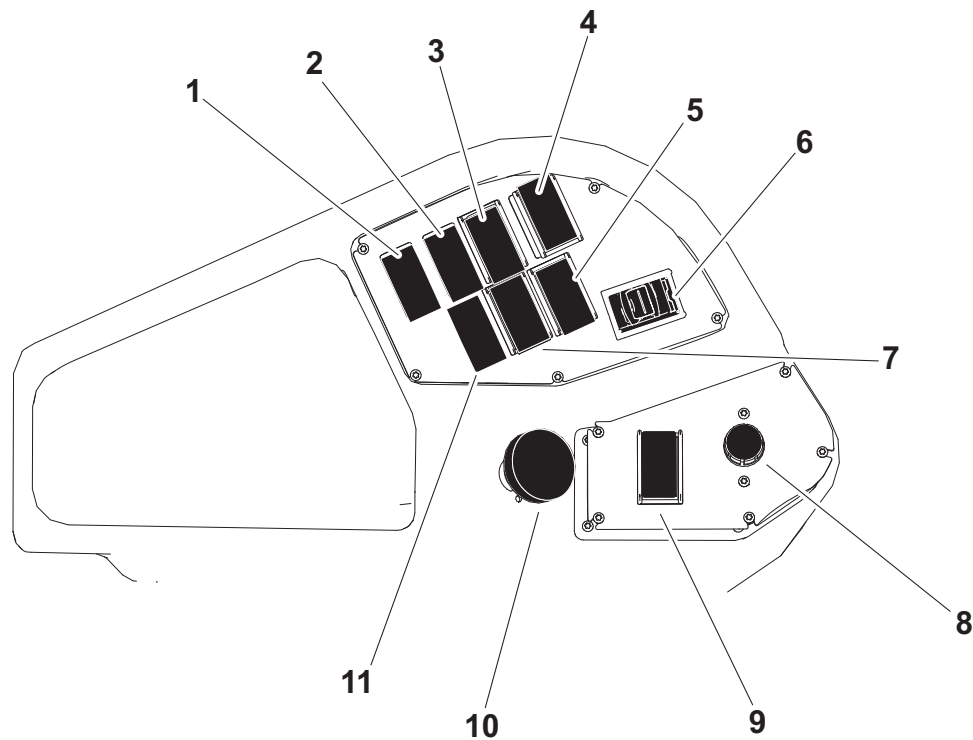

Console, Left

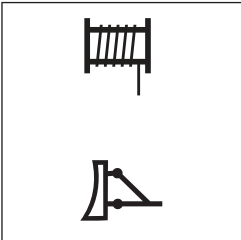
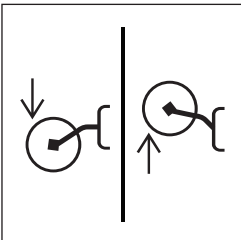
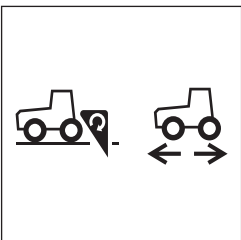
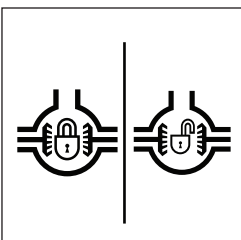

t63om009h21.eps

- | | |
|---------------------------------|----------------------------------------|
| 1. Reel carrier selector switch | 7. Saw/Trench slide control switch* |
| 2. Reel carrier lift control | 8. Cruise control speed dial |
| 3. Dig/Drive | 9. Cruise control selector switch |
| 4. Axle lock switch | 10. Attachment speed/direction control |
| 5. Parking brake switch | 11. Blank |
| 6. Throttle | |
- *If equipped

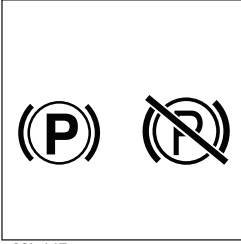
Item	Description	IMPORTANT
<p>1. Reel carrier selector switch</p>  <p>c00ic642w.eps</p>	<p>To enable reel carrier control at backfill blade/reel winder control, press left.</p> <p>To enable to backfill blade control, press right.</p>	
<p>2. Reel carrier lift control</p>  <p>c00ic159w.eps</p>	<p>To lower, press left.</p> <p>To raise, press right.</p>	
<p>3. Dig/Drive</p>  <p>c00ic735h.eps</p>	<p>To select dig, press left.</p> <p>To select drive, press right.</p>	
<p>4. Axle lock switch</p>  <p>c00ic136w.eps</p>	<p>To set axle lock, press left.</p> <p>To release, press right.</p>	<p>NOTICE:</p> <ul style="list-style-type: none"> To set axle lock, operator must be in seat and ground drive direction control must be in neutral. After releasing axle lock, drive tractor in reverse 6' (2m) to fully disengage.

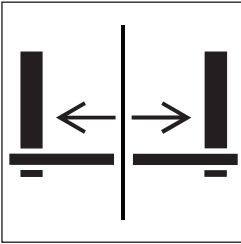
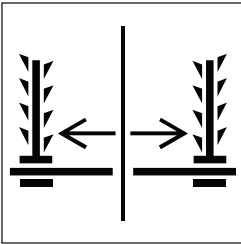
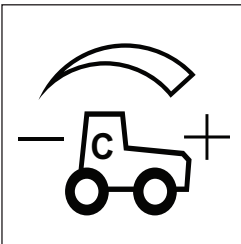
Item	Description	IMPORTANT
<p>5. Parking brake switch</p>  <p>c00ic147w.eps</p>	<p>To set, press left.</p> <p>To release, press right.</p>	
<p>6. Throttle</p>  <p>c00ic133a.eps</p>	<p>To increase speed, move forward.</p> <p>To decrease, pull back.</p>	
<p>7. Saw/Trencher slide control switch</p>  <p>c00ic160w.eps</p>  <p>c00ic155w.eps</p>	<p>To slide saw right, move forward.</p> <p>To slide left, pull back.</p> <p>To slide trencher right, move forward.</p> <p>To slide left, pull back.</p>	
<p>8. Cruise control speed dial</p>  <p>c00ic138w.eps</p>	<p>To increase engine load while using cruise control, turn right.</p> <p>To decrease, turn left.</p>	

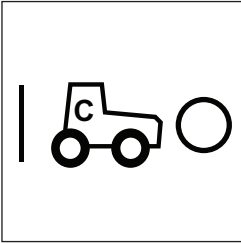
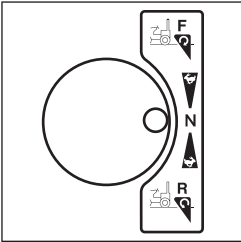
Item	Description	IMPORTANT
<p>9. Cruise control selector switch</p>  <p>c00ic139w.eps</p>	<p>To turn on, press left. To turn off, press right.</p>	<p>Turn on cruise control only when:</p> <ul style="list-style-type: none"> • ground drive motor control is in low • ground drive is in neutral
<p>10. Attachment speed/direction control</p>  <p>c00ic158w.eps</p>	<p>To go faster in either direction, move farther from neutral.</p>	<p>NOTICE: Control does not automatically return to neutral.</p>

Console, Right

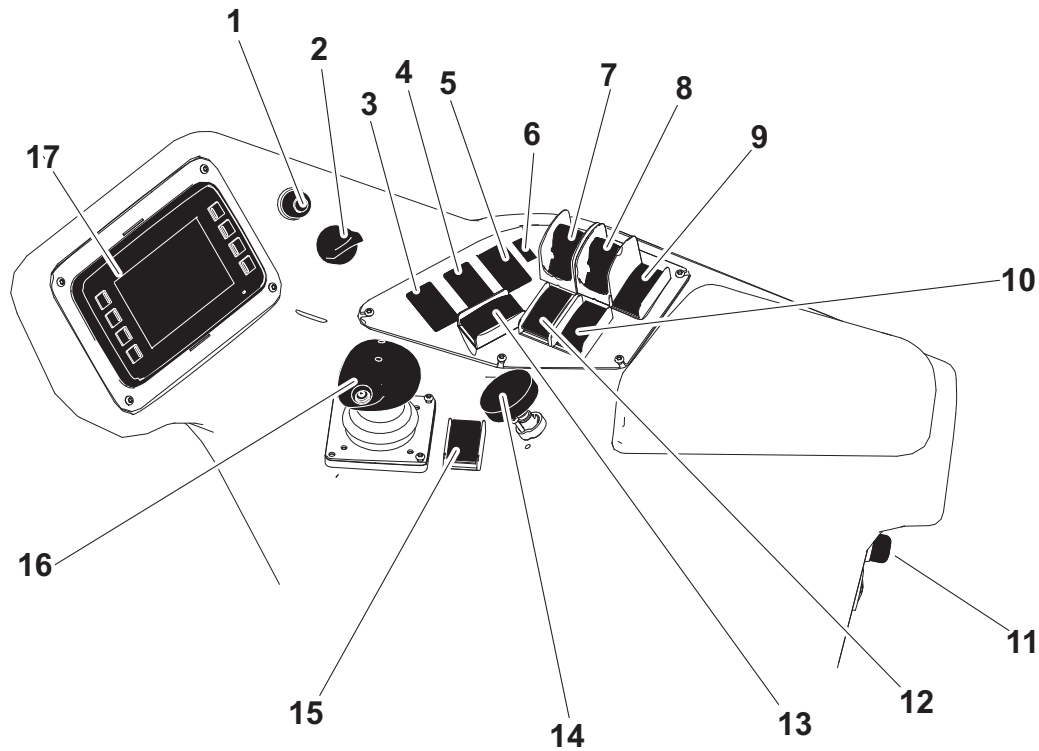

t630m010h21.eps

- | | |
|---------------------------------------------------|------------------------------------------------|
| 1. Horn button | 10. Rear steer adjustment switch |
| 2. Ignition switch | 11. Engine shutdown override |
| 3. Plow lift control | 12. Rear steer switch/Super rear steer switch* |
| 4. Plow swing control | 13. Microtrencher blade tilt/level |
| 5. Plow blade steer control | 14. Ground drive speed hand control |
| 6. USB | 15. Super rear steer mode select* |
| 7. Saw lift/Trencher & microtrencher lift control | 16. Backfill blade/Reel winder control |
| 8. Saw stabilizer control/MT blade raise & lower | 17. Display |
| 9. AST switch/Trench cleaner lift control* | |

*If equipped

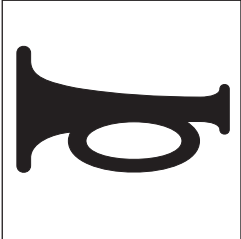
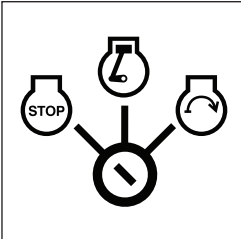
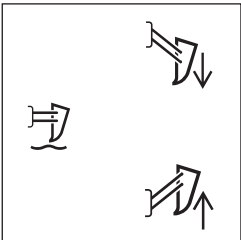
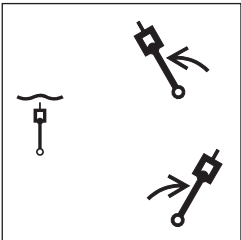
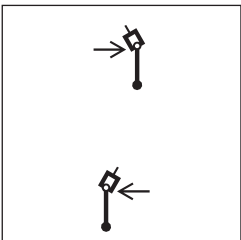
Item	Description	IMPORTANT
<p>1. Horn button</p>  <p>c00ic044h.eps</p>	<p>To sound horn, press.</p>	
<p>2. Ignition switch</p>  <p>c00ic137w.eps</p>	<p>To activate accessories, turn right.</p> <p>To start engine, turn right and hold.</p> <p>To shut off machine, turn left.</p>	<p>See "Drive" on page 83.</p>
<p>3. Plow lift control</p>  <p>c00ic204h.eps</p>	<p>To lower, push forward.</p> <p>To raise, move back.</p> <p>To float, push switch all the way forward until it latches.</p>	<p>NOTICE:</p> <ul style="list-style-type: none"> • If soil conditions allow, operate in float position. • Lower plow into ground before moving control to float position. • Do not raise plow with control in float position.
<p>4. Plow swing control</p>  <p>c00ic202h.eps</p>	<p>To swing right, push forward.</p> <p>To swing left, move back.</p> <p>To float, push switch all the way forward until it latches.</p>	<p>NOTICE:</p> <ul style="list-style-type: none"> • If soil conditions allow, operate in float position. • Lower plow into ground before moving control to float position.
<p>5. Plow blade steer control</p>  <p>c00ic203h.eps</p>	<p>To steer right, press top.</p> <p>To steer left, press bottom.</p>	

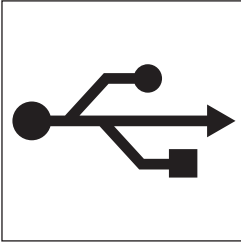
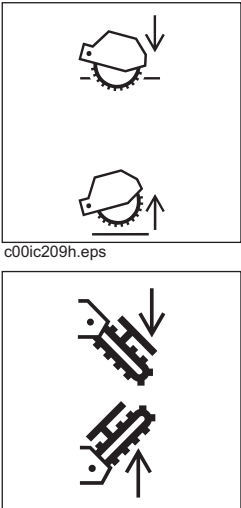
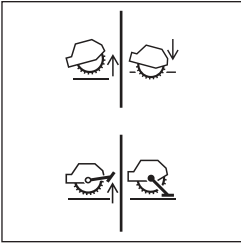
Item	Description	IMPORTANT
<p>6. USB</p>  <p>c00ic250w.eps</p>	<p>Allows technicians to download job log files for optional Depth Meter.</p>	<p>For use only by qualified Ditch Witch technicians.</p>
<p>7. Saw lift/Trencher lift control</p>  <p>c00ic209h.eps c00ic200h.eps</p>	<p>To lower, push forward. To raise, move back.</p>	
<p>8. Saw stabilizer control/ MT blade</p>  <p>c00ic153w.eps</p>	<p>To lower, press top. To raise, press bottom.</p>	

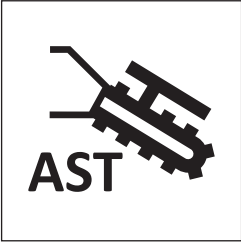
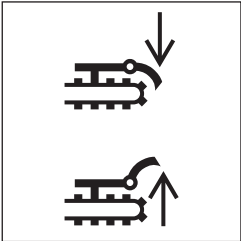
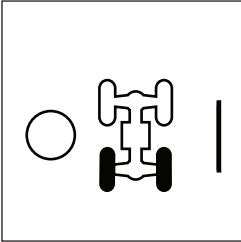
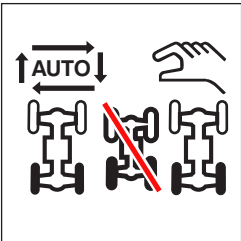
Item	Description	IMPORTANT
<p>9. AST switch/Trench cleaner lift control</p>  <p><small>c00ic797h.eps</small></p>  <p><small>c00ic199h.eps</small></p>	<p>AST switch</p> <p>To activate AST logic, press.</p> <p>Trench cleaner lift control</p> <p>To lower, push forward.</p> <p>To raise, move back.</p>	<p>NOTICE: Display will indicate when to press ATS switch.</p>
<p>10. Rear steer switch/ Super rear steer switch</p>  <p><small>c00ic146w.eps</small></p>  <p><small>c00ic801h.eps</small></p>	<p>Rear steer switch</p> <p>To turn on rear steer, press left.</p> <p>To turn off rear steer, return to center position.</p> <p>To center tracks, press right.</p> <p>Super rear steer switch</p> <p>To engage auto rear steer, press left.</p> <p>To center tracks, return to center.</p> <p>To select manual rear steer, press right.</p>	

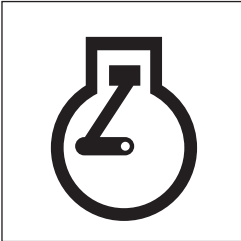
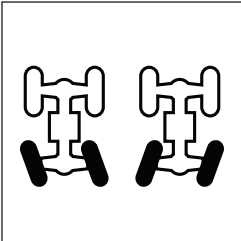
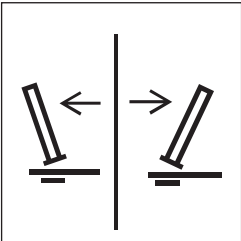
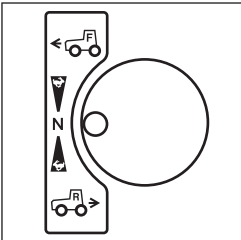
Item	Description	IMPORTANT
<p>11. Engine shutdown override switch</p>  <p>c00ic024w.eps</p>	<p>If engine shutdown indicator comes on, press to delay engine shutdown for 30 seconds.</p>	<p>This control allows a temporary override of engine shutdown.</p> <p>NOTICE: After 30 seconds, engine will again shut down unless fault condition has been cleared on diagnostic gauge.</p>
<p>12. Rear steer adjustment switch</p>  <p>c00ic145w.eps</p>	<p>To move rear tracks left, press and hold left.</p> <p>To move right tracks right, press and hold right.</p>	<p>NOTICE: Visually verify track position.</p>
<p>13. Microtrencher blade tilt/level</p>  <p>c00ic798h.eps</p>	<p>To tilt blade left, press and hold left.</p> <p>To tilt blade right, press and hold right.</p>	
<p>14. Ground drive speed hand control</p>  <p>c00ic157w.eps</p>	<p>To go faster in either direction, move farther from neutral.</p>	<p>This control is disabled in high.</p> <p>NOTICE: Control does not automatically return to neutral.</p>

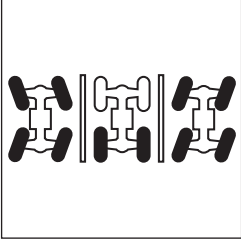
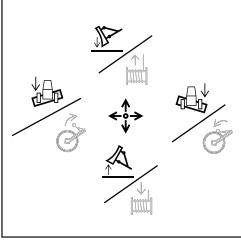
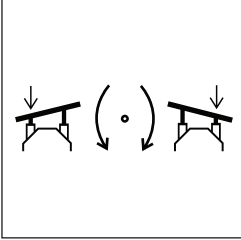
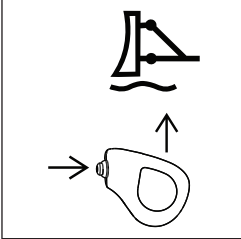
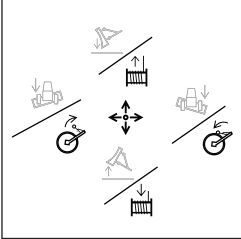
Item	Description	IMPORTANT
<p>15. Super rear steer mode selector switch</p>  <p>c00ic800h.eps</p>	<p>To engage auto-crab mode, press left.</p> <p>To engage auto-center, return to center center.</p> <p>To engage auto-coordinated, press right.</p>	
<p>16. Backfill blade/Reel winder control</p>  <p>c00ic141w.eps</p>  <p>c00ic144w.eps</p>  <p>c00ic143w.eps</p>  <p>c00ic150w.eps</p>	<p>Backfill blade mode:</p> <ul style="list-style-type: none"> • To lower, push. • To raise, pull. • To tilt right side down, move right. • To tilt left side down, move left. • To angle blade to the right, twist right. • To angle blade to the left, twist left. • To float, move forward to end, press button, and release handle. • To remove from float, move back. <p>Reel winder mode:</p> <ul style="list-style-type: none"> • To spool product off, push. • To spool product on, pull. • To move wheel toward spool, move right. • To move wheel away from spool, move left. 	<p>Display indicates float position.</p>

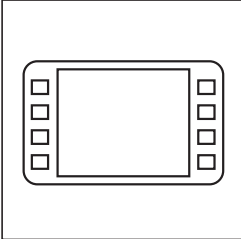
Item	Description	IMPORTANT
<p>17. Display</p>  <p>c00ic152w.eps</p>	<p>Displays graphic symbols for indicators and conditions.</p>	<p>See "Display" on page 59.</p>

Display

Gauges and Indicators

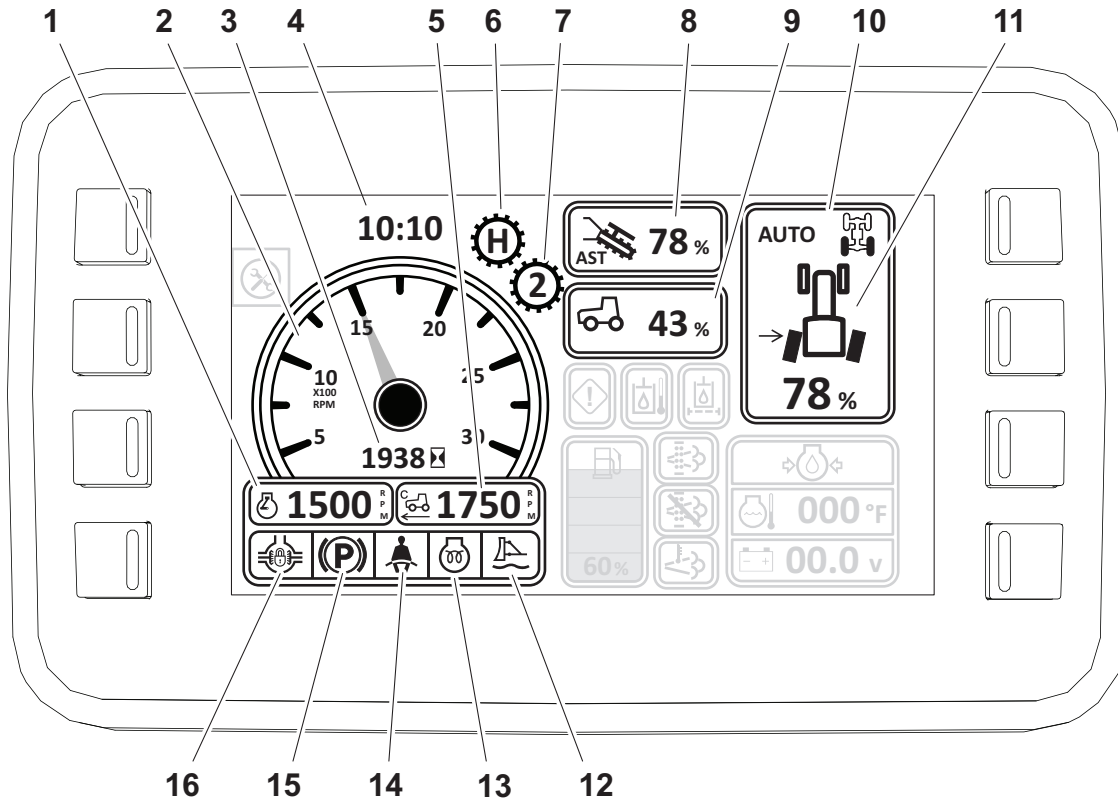

















t630m011h21.eps

- | | |
|--------------------------------------------------------------------------------------------------------------------------------------------------------------------------------------------------------------------------------------------------------------------------------------------------------|----------------------------------------------------------------------------------------------------------------------------------------------------------------------------------------------------------------------------------------------------------------------------------------------------------------------------------------------------------------------|
| <ul style="list-style-type: none"> 1. Engine speed 2. Tachometer 3. Hourmeter 4. Real time clock 5. Cruise control set speed gauge 6. Gearbox status indicator 7. Ground drive speed indicator 8. Attachment drive gauge | <ul style="list-style-type: none"> 9. Ground drive direction gauge 10. Rear steer status indicator 11. Rear steer direction gauge 12. Backfill blade float indicator 13. Cold start wait indicator 14. Operator presence indicator 15. Parking brake indicator 16. Axle lock indicator |
|--------------------------------------------------------------------------------------------------------------------------------------------------------------------------------------------------------------------------------------------------------------------------------------------------------|----------------------------------------------------------------------------------------------------------------------------------------------------------------------------------------------------------------------------------------------------------------------------------------------------------------------------------------------------------------------|

Item	Description	IMPORTANT
1. Engine speed gauge	 Displays numeric value for engine speed.	

Display

Item	Description	IMPORTANT
2. Tachometer	Displays engine speed.	
3. Hourmeter	Displays number of hours engine has been running.	
4. Real time clock	Displays time.	
5. Cruise control set speed gauge	 Displays numeric value for speed.	Only shown when cruise selector switch is on. See "Cruise control selector switch" on page 51.
6. Gearbox status indicator	 Displays current ground drive speed.	Gearbox status is displayed as H (high) or L (low).
7. Ground drive speed indicator	 Displays current ground drive speed.	Ground drive speeds are displayed as 3 (high), 2 (medium), or 1 (low).
8. Attachment drive gauge	<p>Indicates attachment in use and numeric value of attachment drive percentage.</p>  Indicates Plow.  Indicates Rock Saw  Indicates Trencher  Indicates Micro-trencher  AST indicates Anti Stall Technology is active.	<p>Anti Stall Technology (AST) icon color indicates status.</p> <ul style="list-style-type: none"> • White, AST option enabled. • Green, AST is enabled and cruise control is active. • Yellow, AST is active • Red, AST unsuccessful. Attachment and ground drive will shut off. To re-engage the attachment and ground drive, place both in neutral, then reactivate.
9. Ground drive direction gauge	 Displays ground drive direction and numeric value of ground drive percentage.	Part of the start interlock system.
10. Rear steer status indicator	 Displays rear steer mode.	<p>Icon will change to indicate that the system has disabled rear steer.</p> <p>To re-enable rear steer, cycle rear steer mode selector switch.</p>



Item	Description	IMPORTANT
<p>11. Rear steer direction gauge</p>	 <p>Displays rear steer direction and numeric value of tire/track turn percentage.</p>	<p>Icon displays direction of tracks.</p>
<p>12. Backfill blade float indicator</p>	 <p>Lights when backfill blade is in float.</p>	
<p>13. Cold start wait indicator</p>	 <p>Lights when cold start aids are active.</p>	<p>Wait until light turns off before starting engine.</p>
<p>14. Operator presence indicator</p>	 <p>Lights when operator is in seat.</p>	<p>Part of the start interlock system.</p>
<p>15. Parking brake indicator</p>	 <p>Lights when parking brake is set.</p>	
<p>16. Axle lock indicator</p>	 <p>Lights when axle lock is set.</p>	

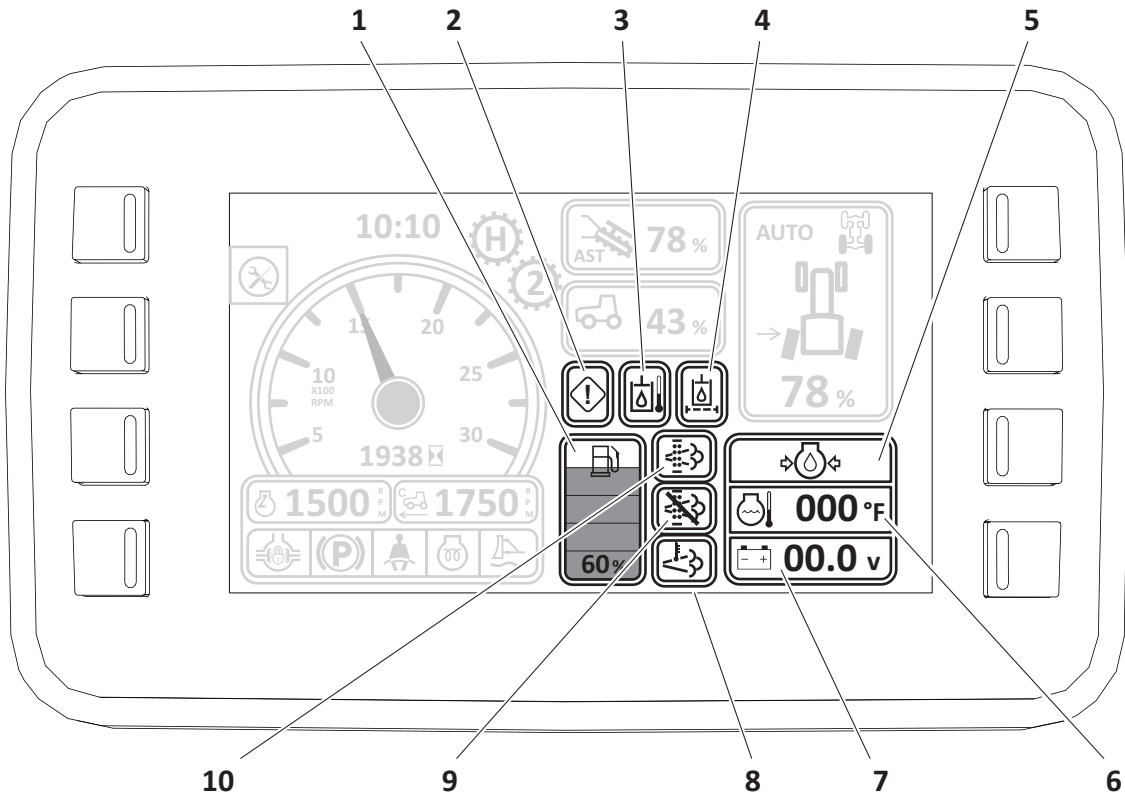







Gauges and Indicators



t63om013h21.eps

- | | |
|------------------------------------------|----------------------------------------|
| 1. Fuel gauge | 6. Engine coolant temperature gauge |
| 2. Engine caution/stop indicator | 7. Voltmeter |
| 3. Hydraulic fluid temperature indicator | 8. High exhaust temperature indicator |
| 4. Hydraulic fluid filter indicator | 9. Exhaust cleaning disabled indicator |
| 5. Engine oil pressure indicator | 10. Exhaust cleaning indicator |



Item	Description	IMPORTANT
1. Fuel gauge	 Displays fuel level.	See "Approved Fuel" on page 149.
2. Engine caution/stop indicator	 Lights yellow when engine needs attention.  Lights red when operator needs to stop engine.	

Item	Description	IMPORTANT
3. Hydraulic fluid temperature indicator	 Lights when hydraulic fluid temperature is too high.	
4. Hydraulic fluid filter indicator	 Lights when hydraulic filter is restricted.	During cold weather, light will stay on until hydraulic fluid reaches operating temperature.
5. Engine oil pressure indicator	 Lights when engine oil pressure is too low.	
6. Engine coolant temperature gauge	 Displays engine coolant temperature.	
7. Voltmeter	 Displays machine voltage.	
8. High exhaust temperature indicator	 Lights when exhaust temperatures are high.	May light when exhaust cleaning is occurring.
9. Exhaust cleaning disabled indicator	 Lights when operator has disabled exhaust cleaning.	See "Exhaust Cleaning" on page 67.
10. Exhaust cleaning indicator	 Lights when exhaust cleaning is needed.	If indicator flashes or changes color, follow on-screen instructions. See "Exhaust Cleaning" on page 67.

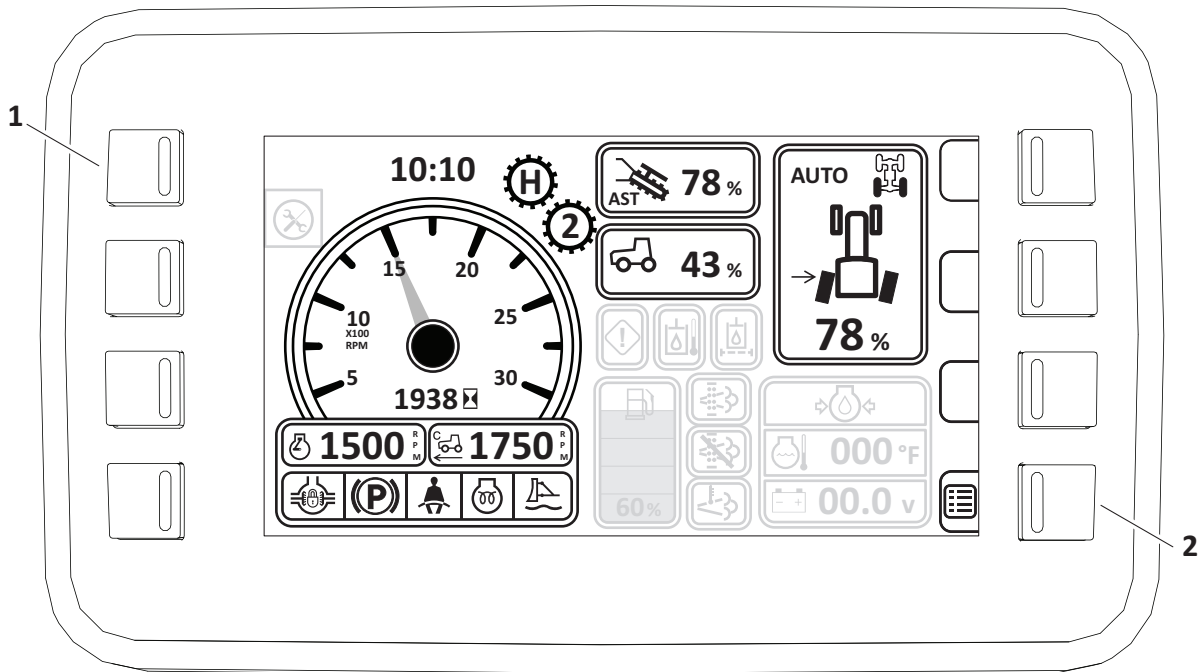
Soft Keys



t63om092h21.eps

Item	Description	IMPORTANT
1. Hide/Recall diagnostics key	 To hide diagnostic message, press twice. To recall, press once.	
2. Main menu key	 To select main menu, press.	

Main Menu

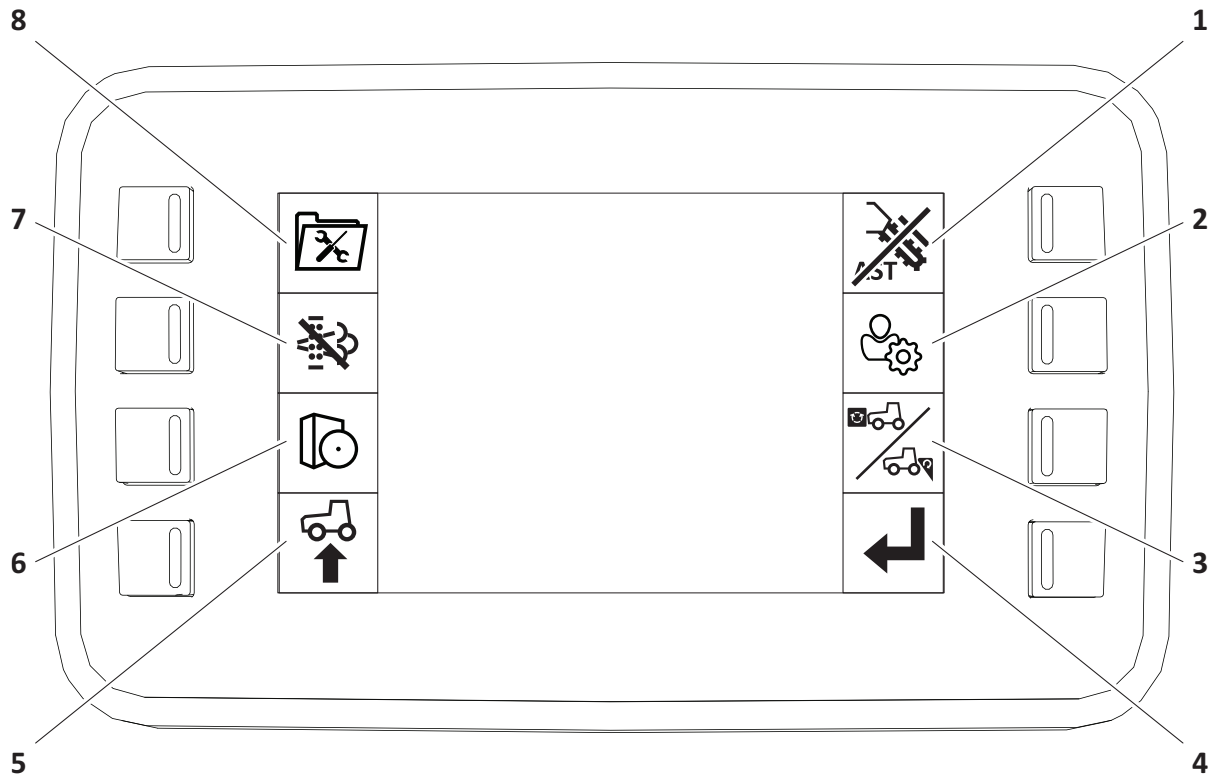

t63om084h21.eps

- | | |
|------------------------------------|------------------------------|
| 1. Anti Stall Technology (AST) key | 5. Machine configuration key |
| 2. User settings key | 6. Software version key |
| 3. Attachment configuration key | 7. Exhaust cleaning key |
| 4. Return key | 8. Diagnostic menu key |

Item	Description	IMPORTANT
1. Anti Stall Technology (AST) key	To toggle AST, press.	
2. User settings key	To customize settings, press.	Display brightness, clock settings, units of measure, and language can be adjusted in this screen.
3. Attachment configuration key	To access attachment configuration screen, press.	Front and rear attachment configurations can be set in this screen.
4. Return key	To return to main screen, press.	

Display

Item	Description	IMPORTANT
<p>5. Machine configuration key.</p>	<p>To access machine configuration menu, press.</p>	
<p>6. Software version key</p>	<p>To view software version, press.</p>	
<p>7. Exhaust cleaning menu key</p>	<p>To display exhaust cleaning information, press</p>	<p>Parked cleanings can be initiated and automatic exhaust cleanings can be enabled/disabled in this screen.</p>
<p>8. Diagnostics key</p>	<p>To display engine and controller diagnostic codes, press.</p>	<p>For use only by qualified Ditch Witch technicians.</p> <p>If diagnostic codes are displayed, contact your Ditch Witch dealer.</p>

Display Pop-Up Messages

Display will automatically show pop-up messages for start interlock and exhaust cleaning systems when needed. Screen will return to normal once conditions are met.

Start Interlock

For machine to start, operator must be in seat and ground drive direction control must be in neutral. If one or more of these conditions is not met, a pop-up message will appear.

Exhaust Cleaning

A pop-up message will appear when an exhaust cleaning is needed.

NOTICE: Failure to complete the exhaust cleaning when required can cause damage to the engine.

When pop-up message appears:

1. Ensure machine is away from combustible material.
2. Set parking brake.
3. Set engine at low throttle.
4. Ensure that engine temperature has reached at least 140°F (60°C).
5. Follow on-screen prompts to initiate exhaust cleaning.

After exhaust cleaning is initiated, another pop-up message will be displayed with the estimated time remaining until process is complete.

IMPORTANT: If exhaust cleaning cannot be initiated when pop-up message occurs, follow on-screen prompts to return to main screen. Pop-up message will return to prompt exhaust cleaning at a later time.

Display, Trench Depth Meter

Trench Indicators

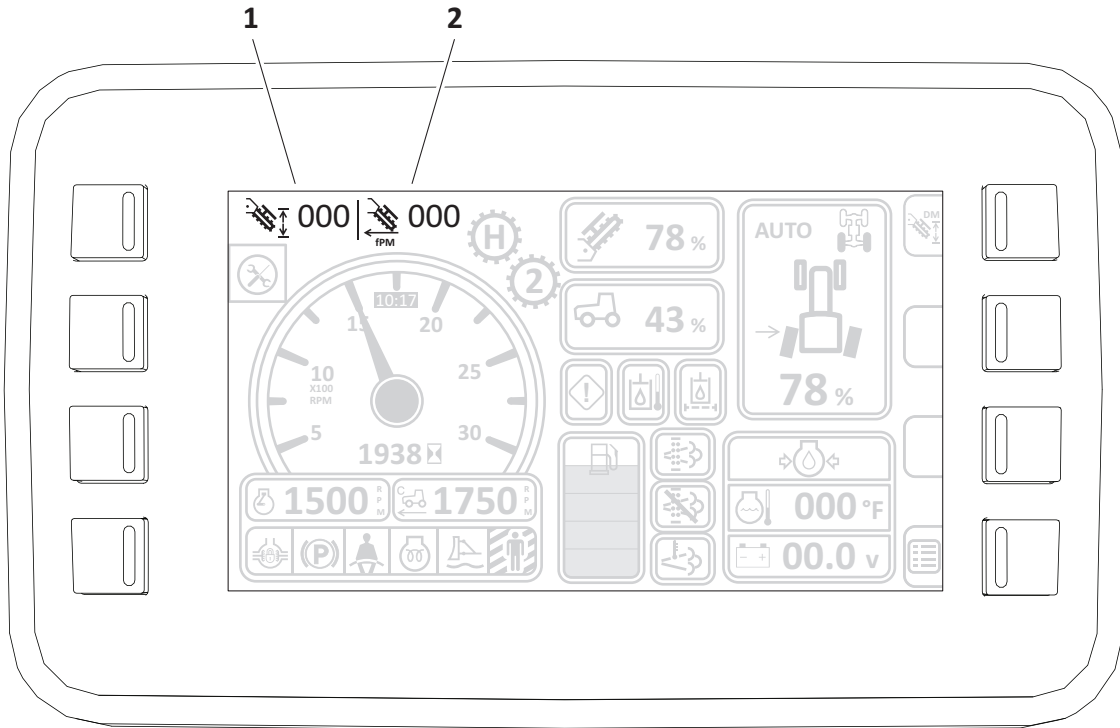

t630m098h21.eps

Item	Description	IMPORTANT
1. Depth indicator	Displays current trench depth.	
2. Trench rate indicator	Displays current trench speed.	

Soft Keys

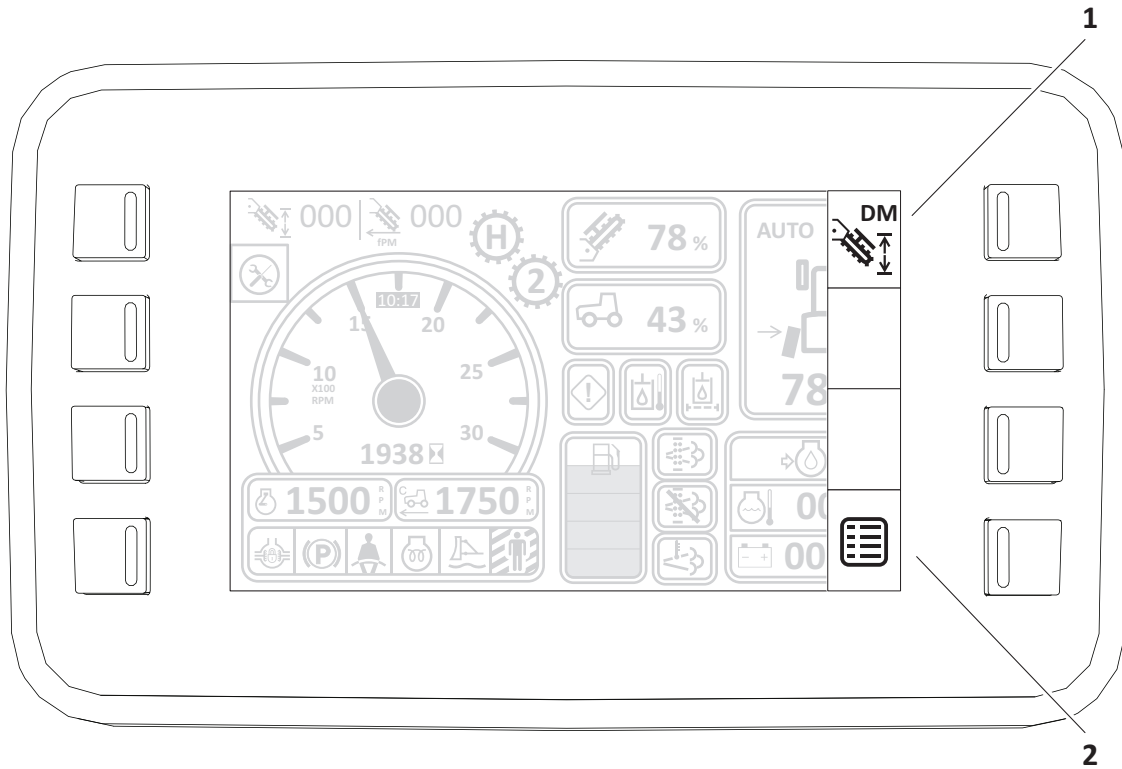

t63om099h21.eps

Item	Description	IMPORTANT
1. Depth meter screen key	To enter depth meter screen, press.	
2. Main menu key	To return to main menu, press.	



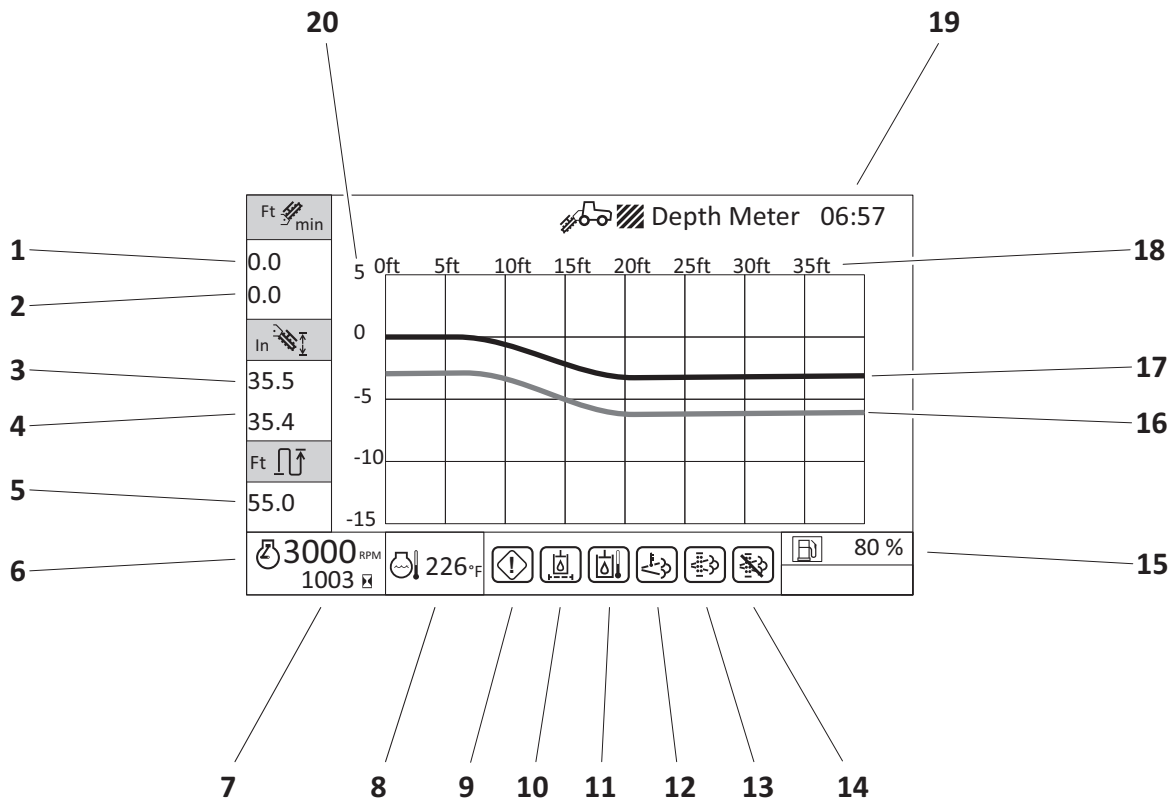







Depth Meter Screen



t63om100h21.eps

- | | |
|--------------------------------------|-------------------------------------------|
| 1. Current speed gauge | 11. Hydraulic fluid temperature indicator |
| 2. Five minute average speed gauge | 12. High exhaust temperature indicator |
| 3. Current depth gauge | 13. Exhaust cleaning indicator |
| 4. Average depth gauge | 14. Exhaust cleaning disable indicator |
| 5. Distance gauge | 15. Fuel gauge |
| 6. Engine speed gauge | 16. Depth graph line |
| 7. Hourmeter | 17. Surface grade graph line |
| 8. Engine coolant temperature gauge | 18. Distance trenched graph axis |
| 9. Engine caution/stop indicator | 19. Real time clock |
| 10. Hydraulic fluid filter indicator | 20. Surface grade graph axis |

Item	Description	IMPORTANT
1. Current speed gauge	Displays current speed.	
2. Five minute average speed gauge	Displays average trench speed from last five minutes.	

Item	Description	IMPORTANT
3. Current depth gauge	Displays current trench depth.	
4. Average depth gauge	Displays average trench depth from current job.	
5. Distance gauge	Displays distance trenched from start of job.	
6. Engine speed gauge	 Displays numeric value for engine speed.	
7. Hourmeter	Displays number of hours engine has been running.	
8. Engine coolant temperature gauge	 Displays engine coolant temperature.	
9. Engine caution/stop indicator	 Lights yellow when engine needs attention.  Lights red when operator needs to stop engine.	
10. Hydraulic fluid filter indicator	 Lights when hydraulic filter is restricted.	During cold weather, light will stay on until hydraulic fluid reaches operating temperature.
11. Hydraulic fluid temperature indicator	 Lights when hydraulic fluid temperature is too high.	
12. High exhaust temperature indicator	 Lights when exhaust temperatures are high.	May light when exhaust cleaning is occurring.
13. Exhaust cleaning indicator	 Lights when exhaust cleaning is needed.	If indicator flashes or changes color, follow on-screen instructions. See "Exhaust Cleaning" on page 67.
14. Exhaust cleaning disabled indicator	 Lights when operator has disabled exhaust cleaning.	See "Exhaust Cleaning" on page 67.
15. Fuel gauge	 Displays fuel level.	See "Approved Fuel" on page 149.

Item	Description	IMPORTANT
16. Depth graph line	Displays trench depth changes.	
17. Surface grade graph line	Displays surface grade changes.	
18. Distance trenched graph axis	Displays reference for distance trenched.	
19. Real time clock	Displays time.	
20. Surface grade graph axis	Displays reference for surface grade.	

Soft Keys

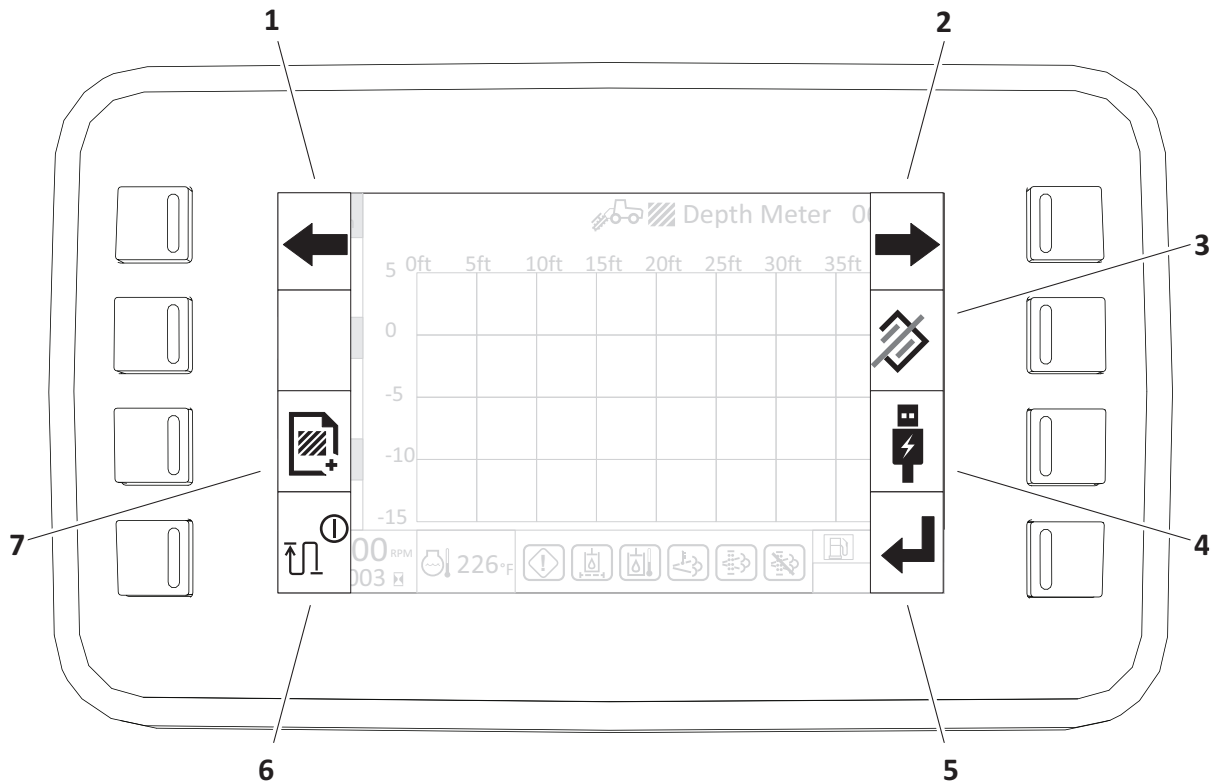

t63om101h21.eps

- | | |
|---------------------------|-----------------------------|
| 1. Manual scroll backward | 5. Exit depth meter screen |
| 2. Manual scroll forward | 6. Pause/Resume current job |
| 3. Delete stored jobs | 7. Start new job |
| 4. Export jobs to USB | |

Item	Description	IMPORTANT
1. Manual scroll backward	To scroll display toward beginning of job, press.	
2. Manual scroll forward	To scroll display toward end of job, press.	
3. Delete stored jobs	To delete stored jobs, press.	
4. Export jobs to USB	To export stored jobs to USB, press.	For use only by qualified Ditch Witch technicians.
5. Exit depth meter screen	To exit depth meter screen, press.	

Item	Description	IMPORTANT
6. Pause/Resume current job.	To pause current job, press. To resume, press.	
7. Start new job	To start new job, press.	

Microtrencher (MT12 only)

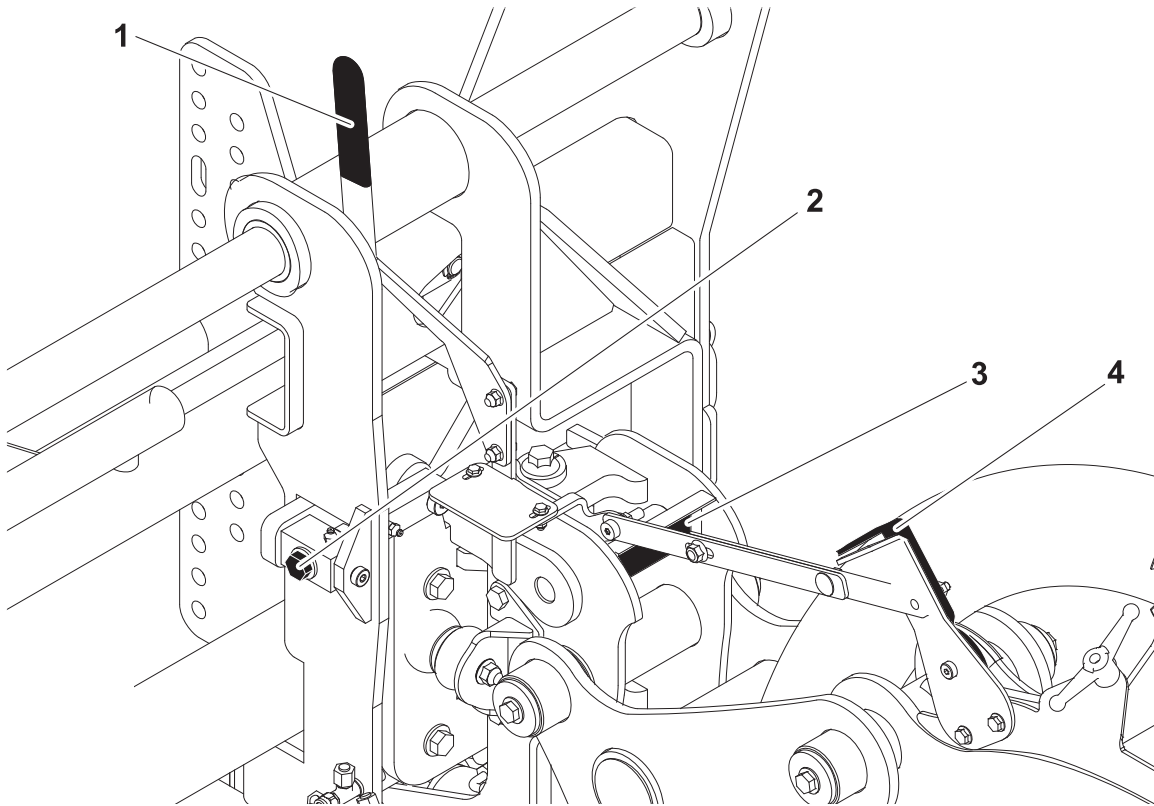

t28om064h.eps

- 1. Swing lock handle
- 2. Manual tilt adjustment
- 3. Bubble level
- 4. Level indicator

Item	Description	IMPORTANT
<p>1. Swing lock handle</p> <div data-bbox="258 1392 500 1633" style="border: 1px solid black; padding: 5px; text-align: center;"> </div> <p>c00ic592h.eps</p>	<p>To lock, move handle toward tractor.</p> <p>To unlock, move handle toward microtrencher.</p>	<p>In most situations, operate with microtrencher locked.</p>
<p>2. Manual tilt adjustment</p>	<p>To adjust left, turn clockwise.</p> <p>To adjust right, turn counterclockwise.</p>	<p>Use with bubble level together to adjust microtrencher to match jobsite conditions.</p> <p>See "Adjust Tilt" on page 107.</p>

Item	Description	IMPORTANT
3. Bubble level	Displays left-to-right microtrencher angle.	Use with manual tilt adjustment to adjust microtrencher to match jobsite conditions. See "Adjust Tilt" on page 107.
4. Level indicator	Indicates base of microtrencher is level with pavement.	Adjust microtrencher base until it is flat on pavement.

Plow

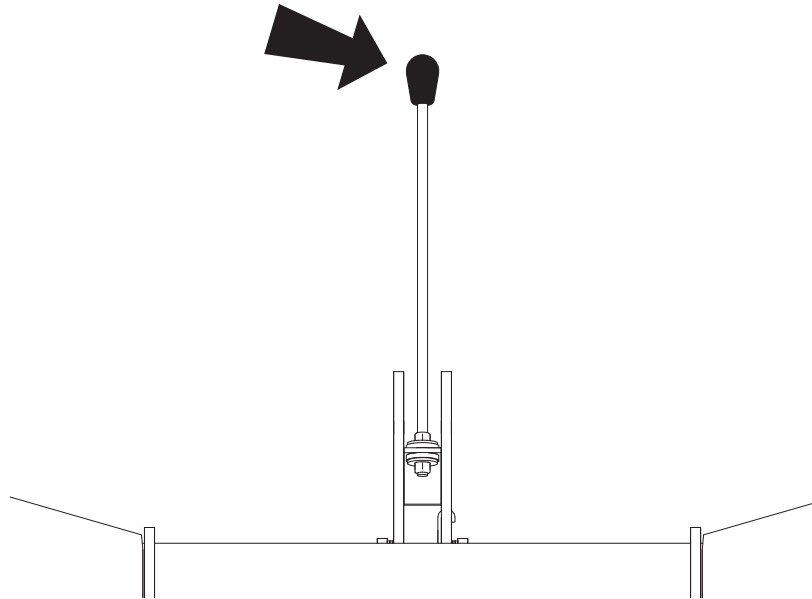

t63om016h21.eps

- Stow lock control

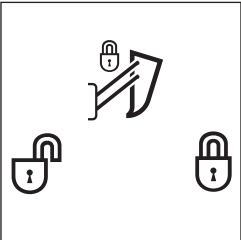
Item	Description	IMPORTANT
<p>Stow lock control</p>  <p>c00ic643w.eps</p>	<p>To lock:</p> <ol style="list-style-type: none"> 1. Raise plow fully. 2. Move control right. 3. Lower plow slightly to engage lock. <p>To release:</p> <ol style="list-style-type: none"> 1. Raise plow slightly. 2. Push stow lock handle to release lock. 	<p>Use this control to lock plow in the raised position.</p>

Seat

Standard

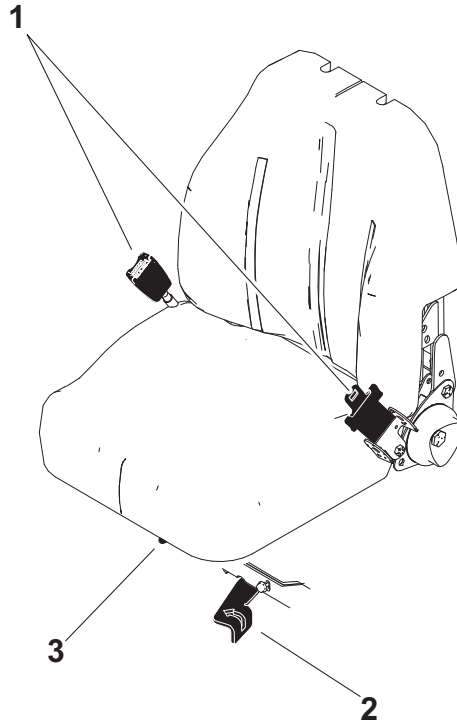

t63om017h21.eps

- 1. Seat belt
- 2. Pivot control
- 3. Slide control

Item	Description	IMPORTANT
1. Seat belt	To fasten, insert latch into buckle. Adjust until seat belt is low and tight. To release, lift top of buckle.	
2. Pivot control	To pivot seat, push lever in direction of arrow and rotate seat to desired position. To lock seat in place, release.	Seat pivots to the right at 0°, 5°, 60°, and 90° and to the left at 30°. Drive tractor with operator's seat facing front. If desired, operate rear attachments with seat pivoted.

Item	Description	IMPORTANT
3. Slide control	To slide seat forward or backward, pull, then adjust seat. To lock seat in place, release.	

Suspension

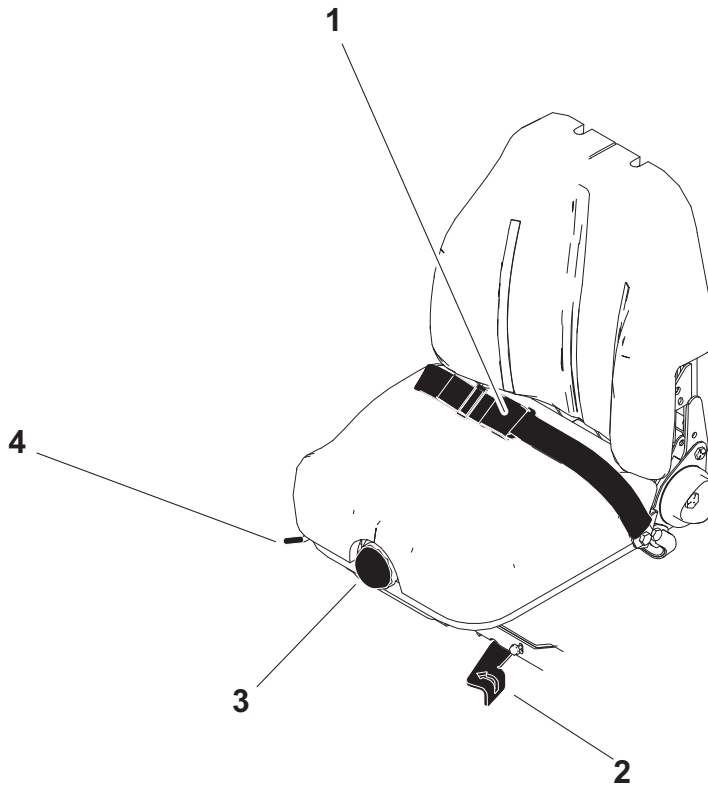

t63om018h21.eps

- 1. Seat belt
- 2. Pivot control
- 3. Suspension control
- 4. Slide control

Item	Description	IMPORTANT
1. Seat belt	<p>To fasten, insert latch into buckle. Adjust until seat belt is low and tight.</p> <p>To release, lift top of buckle.</p>	
2. Pivot control	<p>To pivot seat, push lever in direction of arrow and rotate seat to desired position.</p> <p>To lock seat in place, release.</p>	<p>Seat pivots to the right at 0°, 5°, 60°, and 90° and to the left at 30°.</p> <p>Drive tractor with operator's seat facing front. If desired, operate rear attachments with seat pivoted.</p>

Item	Description	IMPORTANT
3. Suspension control	Adjust dial to approximate body weight for additional comfort.	
4. Slide control	To slide seat forward or backward, pull, then adjust seat. To lock seat in place, release.	

Drive

Chapter Contents

 For additional precautions, see "Safety" and "Prepare" chapters.

IMPORTANT: For more information on how to operate controls, see "Controls" chapter.

Start **84**

Operate **85**

- Slope Guidelines 86
- Reduce Track Wear 87

Shut Down **87**

Start

EMERGENCY SHUTDOWN: Turn ignition switch off.

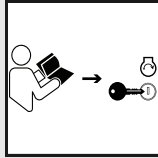

⚠ WARNING Misuse of machine can cause death or serious injury. Read and understand operator's manual and all other safety instructions before use. Know how to use all controls.

To help avoid injury:

- Allow hydraulic fluid time to warm before operating in cold weather. Cold hydraulic fluid can lengthen ground drive stopping time.
- For starting in extreme temperatures, contact your Ditch Witch dealer.



⚠ WARNING Pre-heater. Fire or explosion can cause death or serious injury. Never use starter fluid.

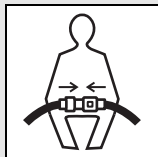

⚠ WARNING Rollover. Crushing can cause death or serious injury. Wear seat belt.

NOTICE: If engine turns but does not start within 30 seconds, engine ECU will prevent starting to allow starter to cool. Wait at least two minutes and try again.

1. Fasten and adjust seat belt.
2. Ensure start interlock conditions are met.
3. Ensure all controls are in neutral.
4. Insert key and activate accessories using ignition switch.
5. **If starting machine in normal conditions,** start engine and run at low throttle under light load for at least three minutes before applying heavier load.

If starting machine in cold weather:

1. When cold start wait indicator turns off, start engine.
2. Warm engine and hydraulic fluid by gradually increasing engine speed for up to 30 minutes.
3. After warmup, carefully operate all hydraulic controls at low throttle until controls operate as described in controls chapter.

Operate

NOTICE:

- Drive carefully in congested areas. Know machine's clearance and turning radius.
- Survey field of vision when operating machine.

1. Turn on optional lights as needed.
2. Raise backfill blade and all attachments.
3. Release parking brake.
4. Adjust throttle.
5. When operating in low or medium:
 - if using the ground drive speed hand control, the ground drive foot control will only increase speed.
 - any opposing signal from controls causes ground drive to stop.

When operating in high, ground drive stops if ground drive speed hand control is moved out of neutral position.

Slope Guidelines

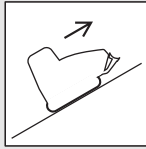
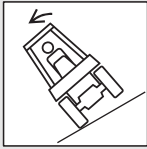

⚠ WARNING Tipover. Crushing can cause death or serious injury. Follow procedure in operator's manual. Drive cautiously.

To help avoid injury:

- Operate at slow speed when on rough terrain.
- Avoid driving across slopes.
- Never jerk control levers. Use a steady, even motion.
- Always operate with heavy end uphill.
- Always drive with attachment low to the ground.

Operating safely on a slope depends upon many factors including:

- distribution of machine weight, including front loading and absence of load
- height of load
- even or rough ground conditions
- potential for ground giving way causing unplanned tilt forward, reverse or sideways
- nearness of ditches, ruts, stumps or other obstructions and sudden changes in slope
- speed
- turning
- braking performance
- operator skill

These varying factors make it impractical to specify a maximum safe operating angle in this manual. It is therefore important for the operator to be aware of these conditions and adjust operation accordingly. Maximum engine angle and braking performance are two absolute limits which must never be exceeded. These maximums are stated below since they are design limits. **These design limits usually exceed the operating limits and must never be used alone to establish safe operating angle for variable conditions.**

Maximum engine lubrication angle: 30°

Maximum service brake retarding force: equal to traction of all four quad tracks

Maximum secondary brake retarding force: equal to traction of two quad tracks

Maximum park brake holding force: equal to traction of all four quad tracks

Reduce Track Wear

Rubber tracks are best suited at soil-based jobsites with minimal rocks and debris. To reduce track wear drive slowly and make wide turns. Avoid the following:

- spinning tracks under heavy load
- turning on sharp objects such as stones, broken concrete, or debris
- quick turns on asphalt or concrete
- driving over curbs or ledges
- driving with track edges pressed against hard walls or curbs
- operating on corrosive materials such as salt or fertilizer

Shut Down

1. When job is complete, move machine to level ground.
2. Stop machine movement.
3. Set parking brake.
4. Lower all unstowed attachments to ground.
5. Return all controls to neutral.
6. Run engine at low throttle with no load for at least three minutes to cool.
7. Shut off machine.
8. If leaving machine unattended, remove key.
9. For maintenance or long-term storage, disconnect battery using battery disconnect switch.

NOTICE: Wait two minutes after shutting off machine before disconnecting battery.

Transport

Chapter Contents



For additional precautions, see "Safety" and "Prepare" chapters.

IMPORTANT: For more information on how to operate controls, see "Controls" chapter.

Lift 90

Haul 90

- Inspect Trailer 90
- Load 91
- Tie Down 92
- Unload 94

Retrieve 95

Lift

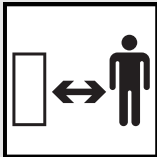

⚠ WARNING Lifted load. Crushing weight can cause death or serious injury. Stay away from lifted load and its range of movement.

This machine is not configured for lifting. If the tractor must be lifted, load machine into a container or onto a platform appropriate for lifting. See “Specifications” on page 195 for size and weight of machine.

Haul

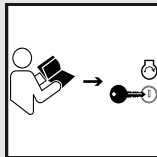

⚠ WARNING Misuse of machine can cause death or serious injury. Read and understand operator's manual and all other safety instructions before use. Know how to use all controls.

To help avoid injury:

- Read trailer operator's manual before loading or transporting machine.
- Ensure tow vehicle has proper tow capacity rating.
- Attach trailer to vehicle before loading or unloading.
- Load and unload trailer on level ground.
- To help prevent trailer sway, load trailer so that 10-15 percent of total vehicle weight (equipment plus trailer) is on tongue.

Inspect Trailer

- Check hitch for wear and cracks.
- Check battery for 12V charge.
- Inspect lights for cleanliness and correct operation.
- Inspect reflectors and replace if needed.
- Check tire pressure.
- Check lug nut torque.
- Ensure trailer brakes are adjusted to come on with tow vehicle brakes.
- Check trailer bed for cracks.

Load

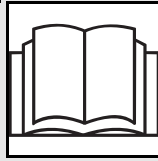

⚠ WARNING Horizontal movement. Crushing can cause death or serious injury. Read and understand operator's manual and all safety instructions before use.

1. Fasten and adjust seat belt with seat facing forward.
2. Start engine.
3. Release parking brake.
4. Select low ground drive speed.
5. Raise attachments, but keep them low and centered. Ensure they are not in float.
6. Slow engine to low throttle and slowly drive tractor to rear of trailer and align with ramps.
7. Drive forward slowly to move machine onto trailer until tiedown position is reached.
8. Lower attachments to trailer bed.
9. Set parking brake.
10. Ensure all controls are in neutral position.
11. Shut off machine.
12. Tie down machine.

Tie Down

Points

Tiedown points are identified by tiedown decals. Securing to truck or trailer at other points is unsafe and can damage machinery.

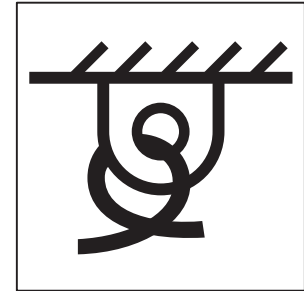

ic1320a.eps

Procedure

Tractor

Loop a transport chain around each tie down point. Ensure tiedowns are tight before transporting.

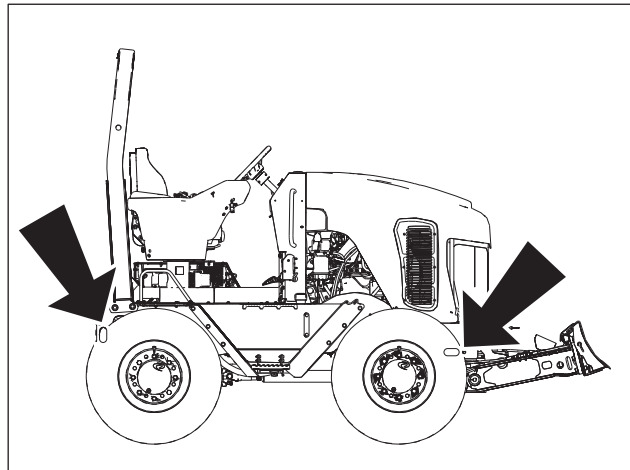

t63om019h21.eps

Centerline Trencher

Lower trencher to trailer bed and chain at attachment frame and through boom. Ensure chains are tight before transporting.

IMPORTANT: If trencher is equipped with a trench cleaner, ensure that trench cleaner shoe is fully raised and extra bolt (found in operator's manual compartment) is installed in appropriate hole for additional support.

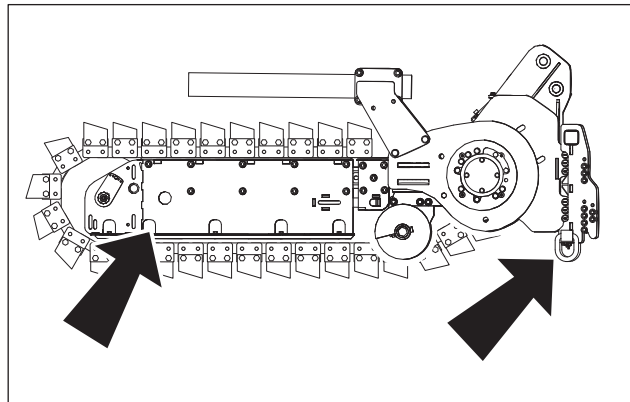

t63om020h21.eps

Traversing Trencher

Lower attachment to trailer bed and chain at attachment frame and through boom. Ensure chains are tight before transporting.

IMPORTANT: If trencher is equipped with a trench cleaner, ensure that trench cleaner shoe is fully raised and extra bolt (found in operator's manual compartment) is installed in appropriate hole for additional support.

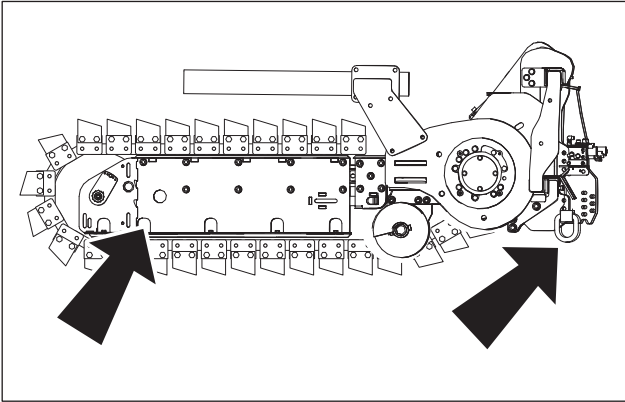

t63om021h21.eps

Reel Carrier

Lower attachment to lowest position as shown.

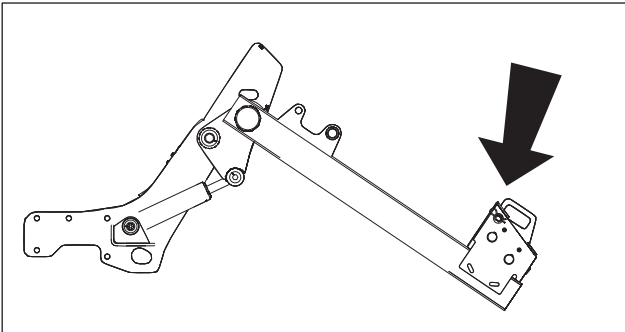

t63om022h21.eps

Plow

Lower attachment to trailer bed and chain at attachment frame and vibrator box. Ensure chains are tight before transporting.

NOTICE: Engage attachment stow lock and swing lock devices in addition to securing at tiedowns.

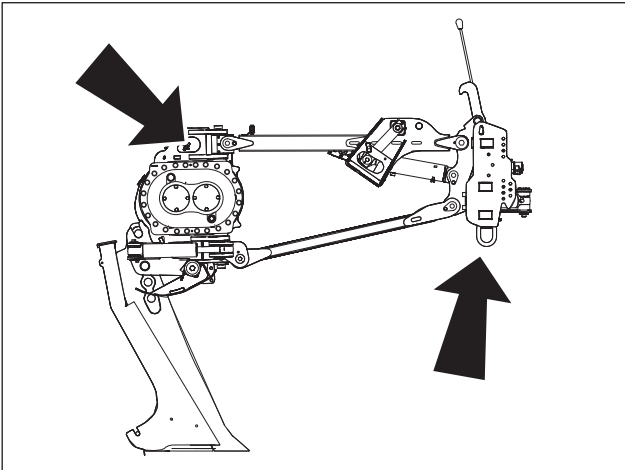

t63om023h21.eps

Unload

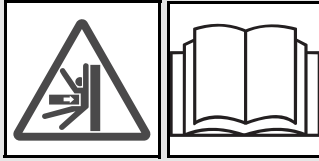

⚠ WARNING Horizontal movement. Crushing can cause death or serious injury. Read and understand operator's manual and all safety instructions before use.

1. Prepare trailer and ramps for unloading.
2. Remove tiedowns.
3. Fasten and adjust seat belt.
4. Start engine.
5. Release parking brake.
6. Raise attachments clear of trailer, but keep them low. Ensure they are not in float.
7. Slow engine to low throttle and slowly back machine down trailer or ramps.

Retrieve

Under normal conditions, tractor should not be towed. If unit becomes disabled and retrieval is needed:

- Tow for no more than 200yd (180m) at less than 1mph (1.6km/h).
 - Use maximum towing force of 1.5 times machine weight.
 - Use towing chains appropriately rated for maximum towing force.
 - Steering will be difficult.
1. Set parking brake if engine is operable.
 2. Block front and rear tires or tracks to prevent unit from rolling.
 3. Attach to tie down points facing towing vehicle.
 4. Locate four plugs (shown) on pump housing. Thoroughly clean area around plugs.
 5. Stop engine.
 6. Remove front two plugs. Some fluid will escape.
 7. Remove relief/check valves. Set aside.
 8. Install plugs and tighten until snug. .

IMPORTANT: Keep check relief/check valves clean while towing.

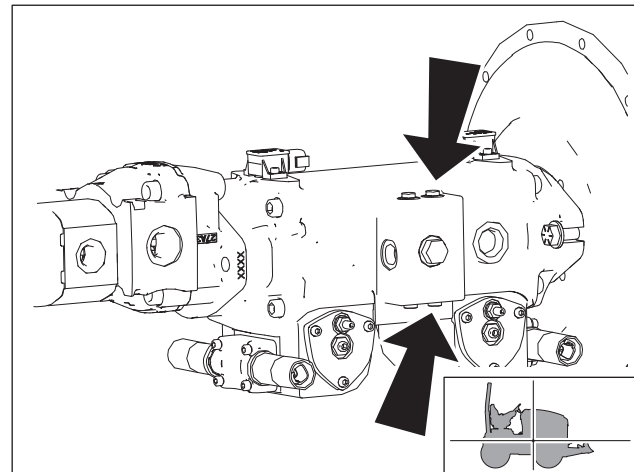

t63om024h21.eps

9. Remove blocks.
10. Fasten and adjust seat belt.
11. Start engine and set throttle to low idle.
12. Release parking brake and stop engine.

IMPORTANT: If engine will not operate, pumps are not turning, or parking break does not release, see "Parking Brake, Mechanical Release" on page 164

13. After towing, reset parking brake and reinstall relief/check valves.

Backhoe

Chapter Contents



For additional precautions, see "Safety" and "Prepare" chapters.

IMPORTANT: For more information on how to operate controls, see "Controls" chapter.

Set Up	98
• Position Tractor	98
• Prepare Backhoe	99
Operate	99
Move Machine	99
Finish Job	101

Set Up

Position Tractor

1. Fasten and adjust seat belt.
2. Start engine.
3. Drive to starting point. Move in line with planned job.

NOTICE: Backhoe may obstruct the forward visibility of the operator. Machines with limited forward visibility should be driven only with the help of a spotter.

4. Return all controls to neutral.
5. Set ground drive speed to low.
6. Lower rear attachment to 6" (150mm) above ground.
7. Lower backfill blade, if equipped.
8. Adjust throttle to low speed.
9. Rotate backhoe operator seat to operation position, as shown.
10. Move to backhoe operator's station.

IMPORTANT: Operator must be in backhoe seat to use backhoe controls.

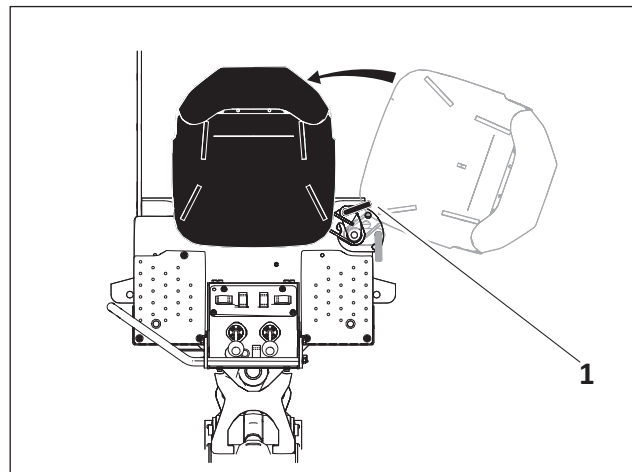

t63om025h21.eps

Prepare Backhoe

1. Rotate seat out of stowed position.
2. Release swing lock.
3. Release stow lock.

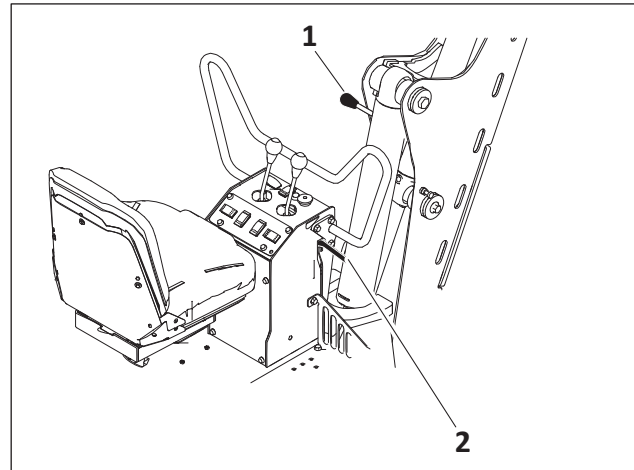

t63om026h21.eps

Operate

1. Start engine.
2. Move to backhoe seat.
3. Lower backfill blade, if equipped.
4. Adjust throttle to desired speed.
5. Dig hole or trench.
 - Keep dipper and boom at right angles as much as possible for maximum power.
 - Keep bucket in line with dipper as much as possible.
 - Position bucket so teeth cut soil. As soil is cut, curl bucket under dipper.
 - Move dipper and bucket together. Increasing engine speed will not increase backhoe force.

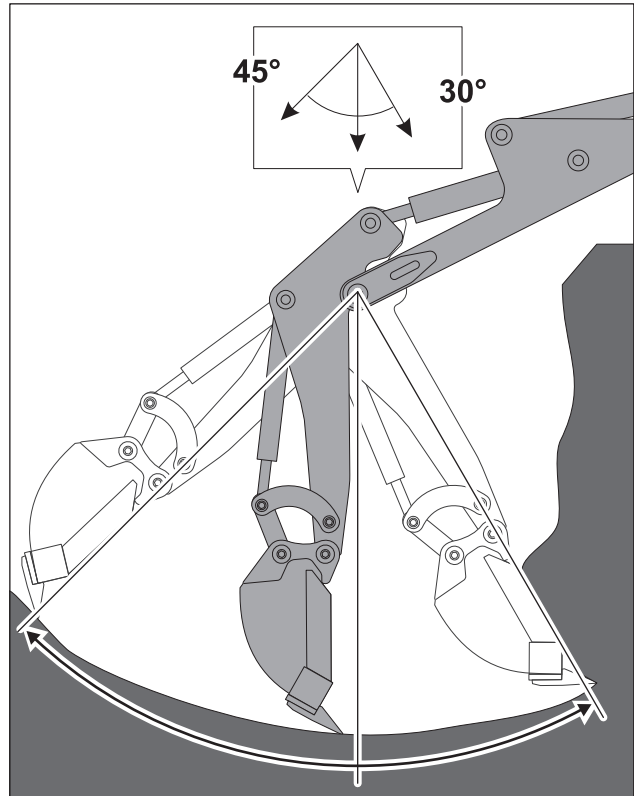

Backhoe_Dig.eps

Move Machine

NOTICE: Only use this method to move machine less than 30' (10m) at one time.

1. Raise stabilizers enough to clear ground.
2. Raise backfill blade, if equipped.
3. Move machine.

IMPORTANT:

- Ensure ground drive direction control is in neutral.
- Ensure attachment speed/direction control is in neutral.
- Ensure range select is in low.

4. Lower stabilizers.

Finish Job

IMPORTANT: For tractor to function once operator has returned to operator station, stabilizers must be raised, remote throttle must be disabled, remote stop must be disengaged, and boom must be stowed and locked.

1. Raise stabilizers fully.
2. Move throttle to low.
3. Lift boom while keeping dipper pointed at ground (shown).
4. Curl bucket closed and move dipper fully toward boom (shown).
5. Engage swing lock.
6. Rotate seat into stowed position.
7. Return to tractor seat and drive a short distance away from work site.
8. Shut off machine.

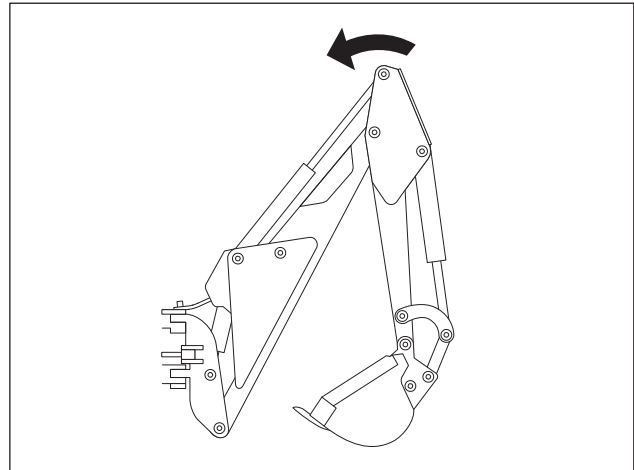

Backhoe_Stow_Boom.eps

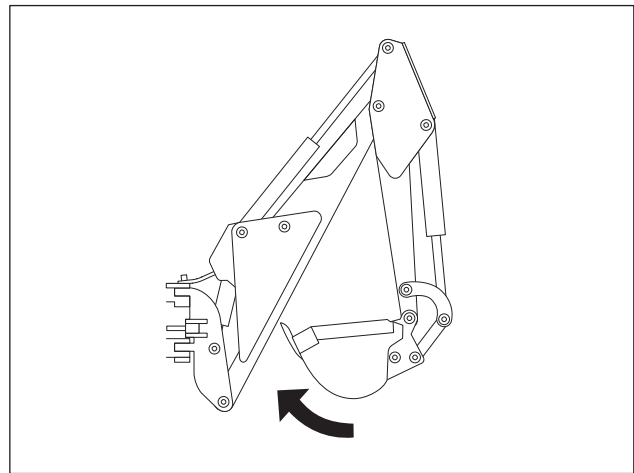

Backhoe_Stow_Bucket.eps

Microtrench

Chapter Contents



For additional precautions, see "Safety" and "Prepare" chapters.

IMPORTANT: For more information on how to operate controls, see "Controls" chapter.

Set Up 104

- Check Bit Clearance 105
- Adjust Trench Depth 106
- Adjust Tilt 107
- Adjust Level Indicator 107
- Prepare Spoils Removal 108

Operate 109

- Use Trench Cleaner 111

Finish Job 112

Set Up

1. MT12: Before first use and after changing bits, check bit clearance. See "Check Bit Clearance" on page 105.
2. Fasten and adjust seat belt.
3. Start engine.
4. Raise microtrencher.
5. Drive to starting point and move in line with planned trench.
6. Lower backfill blade.
7. Set parking brake.
8. MT12: Adjust spoils deflector. See "Spoils Deflector" on page 106.
9. MT12: Lower microtrencher to just above ground and adjust tilt. See "Adjust Tilt" on page 107.
MT16: Lower microtrencher base to ground.
10. Ensure blade is in line with planned trench and that tires are pointing straight ahead.
11. MT12: Adjust level indicator.
12. Prepare spoils removal. See "Prepare Spoils Removal" on page 108.
13. Shut off machine.

Check Bit Clearance

MT12 with blades using 10mm rotating conical bits only

1. Remove blade cover (3).
2. Ensure all bits (1) are properly secured with bit retaining pins are secure.
3. Ensure blade retaining nut (2) is tight.
4. Turn blade by hand and ensure bits do not hit metal frame.

IMPORTANT: If new bits and deflectors are installed, it is normal for bits to hit the deflectors until a portion of the deflector is worn away.

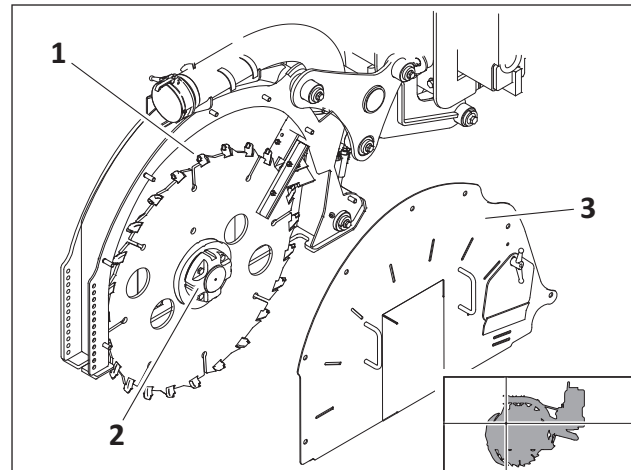

t61om014w19.eps

5. If bits hit frame, repeat steps 2-5 to ensure bits are in the proper location and secured at proper depth.

If bits do not hit frame:

1. Install blade cover.
2. Fasten and adjust seat belt.
3. Start engine.
4. Adjust throttle.
5. Raise microtrencher slightly.
6. Rotate blade slowly and listen for clicking sounds. If clicking sound is present, turn off tractor and repeat steps 1-6.

Adjust Trench Depth

Spoils Deflector

MT12 only

1. Remove blade cover.
2. Remove hardware that retain the inside spoils deflector (shown).
3. Position spoils deflector.

IMPORTANT: For best spoils removal, set the spoils deflector as close to the blade as possible.

4. Reassemble.

NOTICE: Overtightening nuts will distort deflector.

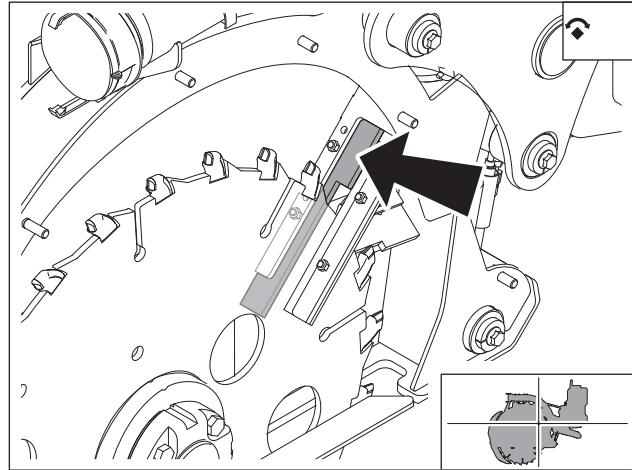

128om066h.eps

Adjust Tilt

IMPORTANT: Microtrenching requires good contact between microtrencher frame and the surface being cut. Lift, level and tilt microtrencher to match jobsite conditions.

MT12 only

1. Lower microtrencher.
2. Loosen four clamp bolts (2, and two on other side of mount).
3. Adjust manual adjustment turn screw (1) and watch bubble level (3) until desired tilt is achieved.
4. Tighten clamp bolts.

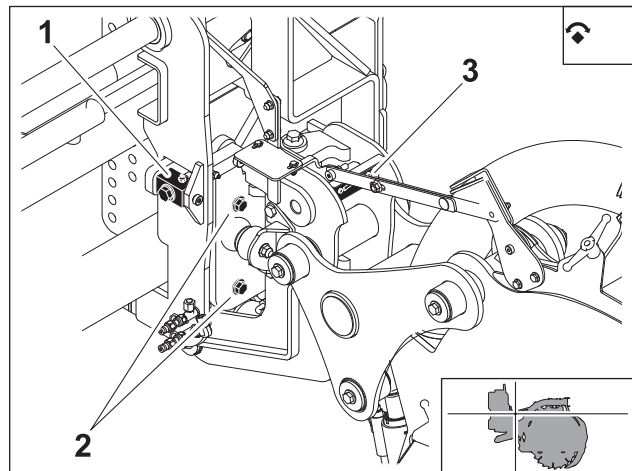

t28om068h.eps

Adjust Level Indicator

MT12 only

1. Remove blade.
2. Position base of microtrencher flat on pavement.
3. Loosen bolts (1) in adjustable link and align moving pointer (2) with fixed pointer.
4. Tighten bolts.

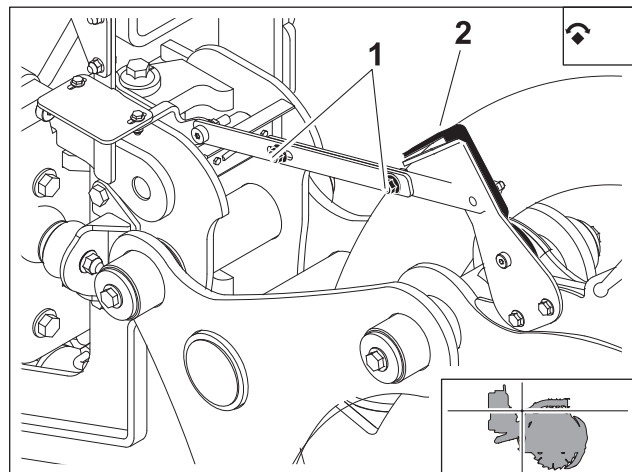

t28om088h.eps

Prepare Spoils Removal

The MT12 is designed to operate optimally with an 800cfm vacuum excavator to remove spoils. If vacuum excavator is not available, set up machine to operate without it and use other dust control methods.

The MT16 is designed for use with an 800cfm or larger vacuum excavator.

With Vacuum Excavator

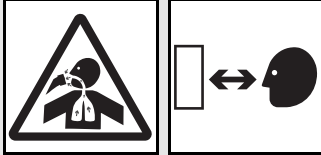

⚠ DANGER Suction. Suffocation will cause death. Keep hose end away from face.

IMPORTANT: Read vacuum excavator operator's manual for operation, safety and service information.

1. Shut off vacuum excavator.
2. Connect vacuum hose on excavator to vacuum hose on tractor.
3. Operate vacuum excavator at full speed for best results. Full vacuum flow to microtrencher is needed for best spoils removal.

IMPORTANT: Ensure vacuum hoses are clear, vacuum filters are clean, and separator canister is empty prior to operation.

Without Vacuum Excavator

MT12 only

1. Cap vacuum hose on tractor.
2. Remove chute plates (1).
3. Install spoils chutes (2).

NOTICE: Note orientation of spoils chute as indicated by decal on chute.

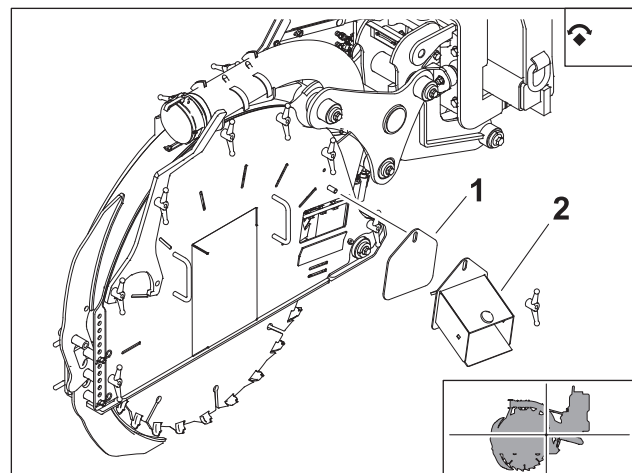

t28om069h.eps

Operate

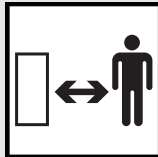
**WARNING**

Thrown objects. Impact can cause death or serious injury. Stay away.

1. Start machine.
2. Set to low throttle.
3. Lower backfill blade to ground.
4. Set speed.

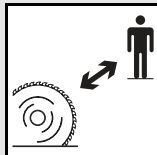
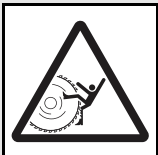
**DANGER**

Moving digging teeth. Contact will cause death or serious injury. Stay at least 6' (1.8 m) away.

To help avoid injury:

- Allow 3' (1m) between digging teeth and obstacle. Machine may jerk when digging starts.
- Keep everyone at least 6' (1.8m) from machine, attachments, and their range of movement.
- Only operate with blade cover and chutes or chute plates installed.

5. Set to high throttle.
6. Slowly lower blade to full depth.

IMPORTANT:

- When possible, lower microtrencher into softer material and then move into harder or abrasive material. For example, lower microtrencher into dirt at shoulder before cutting across road.
- Apply microtrencher downforce as needed to ensure front of frame is in contact with or slightly above the ground.

Operate

7. Raise backfill blade.
8. Release parking brake.
9. Set trenching speed.

NOTICE:

- Do not attempt to trench a radius smaller than 40' (12.2m).
- Release microtrencher swing lock when cutting curved trenches.

IMPORTANT:

- Ground drive speed and direction can be controlled with foot pedal or hand control. When trenching, set ground drive speed with hand control. Use foot pedal to temporarily adjust speed if digging conditions change for a short distance.
- If cutting a curved trench smaller than a 40' (12.2m) radius, make a series of straight cuts.

Use Trench Cleaner

NOTICE: Do not start trench with trench cleaner in place.

Use correct trench cleaner for blade. Two trench cleaners are available: one for blades 1" (25mm) or less and one for blades wider than 1" (25mm).

1. Start trench and move forward a short distance.
2. Stop forward movement.
3. Set parking brake.
4. Raise blade and stop rotation.
5. Raise microtrencher.
6. Shut off machine.
7. Remove trench cleaner from stowed position (shown).

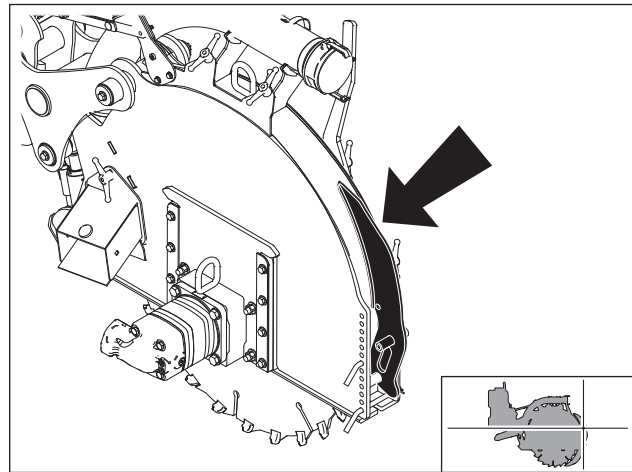

t28om087h.eps

8. Set trench cleaner to desired depth by matching the number of holes below trench cleaner mounting pin to number of holes below blade motor, as shown. Trench cleaner should be close to, but not touching, blade.

NOTICE: Operating microtrencher with trench cleaner in wrong position can damage trench cleaner and blade.

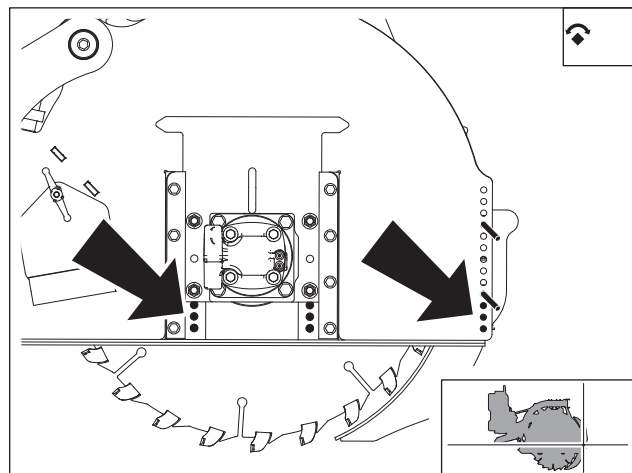

t28om071h.eps

9. Fasten and adjust seat belt.
10. Start engine.
11. Start blade rotation and slowly lower microtrencher into trench to continue trenching.
12. When finished, stop trenching and return trench cleaner to stowed position.

Finish Job

1. When trench is complete, stop machine movement.
2. Adjust to low throttle.
3. Raise blade.
4. When blade is fully raised, stop blade rotation.
5. Raise microtrencher.
6. Drive a short distance away from work site.
7. Shut off machine.
8. MT12: Wash bits and mounting blocks with high-pressure water before parking machine overnight.

Plow

Chapter Contents



For additional precautions, see "Safety" and "Prepare" chapters.

IMPORTANT: For more information on how to operate controls, see "Controls" chapter.

Set Up 114

- Position Tractor 114
- Attach Product 114
- Prepare Tractor 115

Operate 116

- Special Plowing 117

Finish Job 118

Set Up

Position Tractor

IMPORTANT: If material must be at a constant depth, dig starting and target trenches.

1. Fasten and adjust seatbelt.
2. Start engine.
3. Drive to starting point. Move in line with planned plow path.
4. Set parking brake.
5. Lower backfill blade, if equipped.
6. If equipped with combo, enable plow operation.
7. Lower plow to starting point of trench.
8. Shut off machine.

Attach Product

Pull Product

1. Insert material into pulling grip, as shown.
2. Tape grip with duct tape.

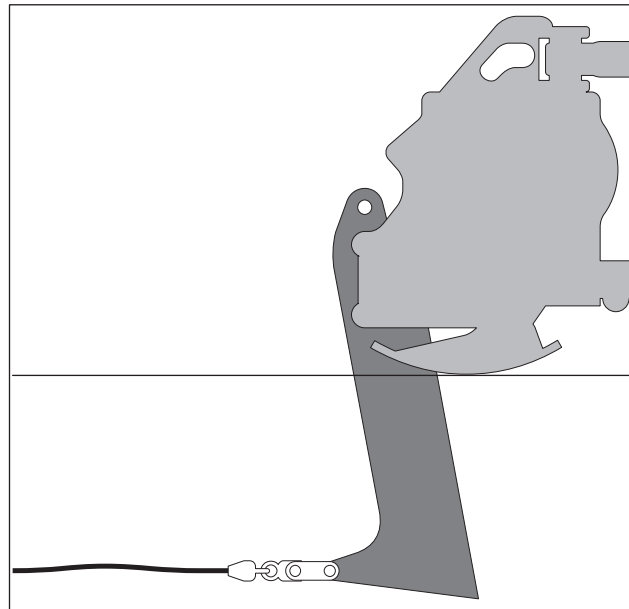

Plow_Pull.eps

Feed Product

IMPORTANT: Use only genuine Ditch Witch cable guide.

1. Remove cable guide.
2. Feed material through tube from top to bottom, as shown.
3. Replace cable guide and tighten fasteners.
4. Secure cable.

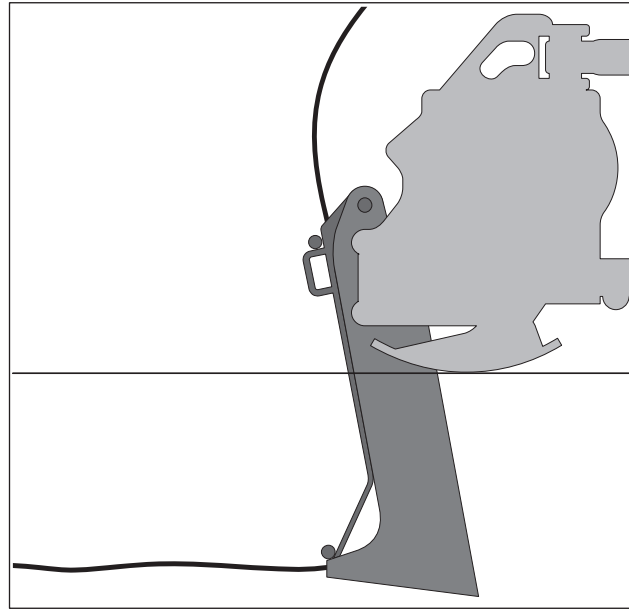

Plow_Feed.eps

Prepare Tractor

1. Fasten and adjust seat belt.
2. Start engine.
3. Set to low throttle.
4. Release parking brake.
5. Select low ground drive speed.
6. Lower reel carrier, if equipped, to operating position.

NOTICE: Use extreme caution when operating reel carrier on sloped surfaces.

7. Raise backfill blade, if equipped.
8. Turn seat to desired position.
9. Engage axle lock.

Operate

1. If equipped with combo, enable plow operation.
2. Lower plow blade into ground.
3. Set plow lift to float.
4. Drive forward slowly.
5. Start plow vibration. PLOW WILL VIBRATE.

NOTICE:

- Do not operate vibrator unless plow is in the ground.
- Do not drive in reverse with plow blade in the ground.

6. Slowly increase vibration to desired speed.
7. Set plow swing to float.
8. Set to full throttle.
9. Reduce attachment speed to the point with the least tractor vibration and the highest ground drive speed possible without track slippage. Adjust vibrator speed if ROPS vibrates excessively.
10. Monitor product for damage during plowing.

Special Plowing

NOTICE: Oversteering blade may damage blade or cable.

Your Ditch Witch® equipment allows you to plow four ways: normal plowing, offset plowing (1), coordinated plowing (2), and crabbing (3).

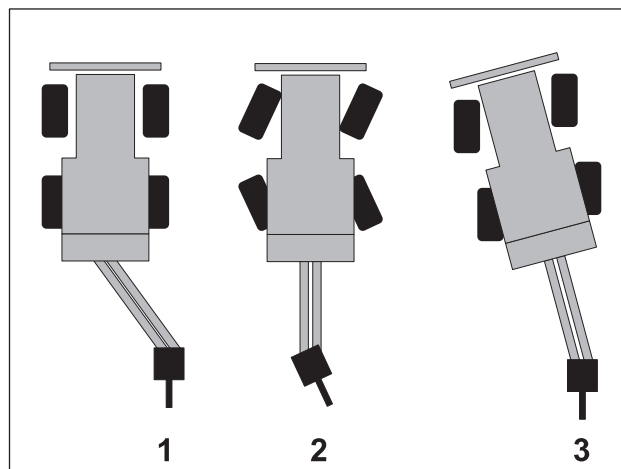

Plowing.eps

Offset Plowing

Offset plowing can be used to plow next to a road while keeping tracks on a more stable surface or in similar conditions.

1. Move plow to planned trench line.
2. Position blade parallel to direction of tractor frame.

Coordinated Plowing

Coordinated plowing can be used to turn a tight circle around a jobsite obstacle or in similar conditions.

1. Engage rear steer.
2. Position the tracks as shown above (2).
3. Slowly move tractor forward.
4. Plow as normal.

IMPORTANT: When coordinated plowing, keep plow blade straight or in the same angle position as rear tracks.

Crab Plowing

Crab plowing can be used to plow along the edge of jobsite or in similar conditions.

1. Engage rear steer.
2. Position the tracks as shown above (3).
3. Slowly move tractor forward.
4. Plow as normal.

Finish Job

1. When installation is complete, move plow swing and plow lift out of float.
2. Stop machine movement.
3. With vibrator running, raise plow to ground level while reducing vibrator speed.

NOTICE: Do not operate vibrator when plow is out of the ground.

4. Stop vibration.
5. Return seat to the drive position.
6. Set parking brake.
7. Lower backfill blade, if equipped.
8. Shut off machine.
9. Remove product from plow.
10. Fasten and adjust seat belt.
11. Start machine.
12. Swing plow to center position and engage stow lock.
13. Release parking brake.
14. Raise backfill blade, if equipped.
15. Disengage axle lock. After disengaging axle lock, drive tractor in reverse 6' (2m) to fully disengage.
16. Drive a short distance away from work site.
17. Shut off machine.

Reel Carrier

Chapter Contents



For additional precautions, see "Safety" and "Prepare" chapters.

IMPORTANT: For more information on how to operate controls, see "Controls" chapter.

Set Up **120**

- Adjust Reel Winder 120
- Prepare to Plow 120

Operate **120**

Finish Job **121**

Set Up

Install Reel

1. Start engine.
2. Lower reel carrier.
3. Shut off machine.
4. Install reel.

Prepare to Plow

1. Fasten and adjust seat belt.
2. Start engine.
3. Drive to beginning of planned plow path.

NOTICE: Large reels of conduit or cable may obstruct the forward visibility of the operator. Machines with limited forward visibility should be driven only with the help of a spotter.

4. Set parking brake and verify parking brake indicator is on.
5. Lower backfill blade, if equipped.

Operate

1. Lower plow.
2. Shut off engine.
3. Attach service line to reel.

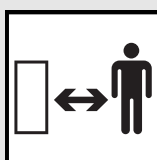

WARNING

Moving parts. Contact can cause serious injury.
Stay away.

4. Fasten and adjust seat belt.
5. Start engine.
6. Enable reel winder operation.
7. Lower reel winder arm until track meets reel flange.
8. Wind service line.

Finish Job

1. When finished winding, raise reel winder arm.
2. Set to low throttle.
3. Enable backfill blade controls.
4. Raise backfill blade, if equipped.
5. Release parking brake.
6. Follow directions in "Plow" on page 101 to begin plowing.

Trench

Chapter Contents



For additional precautions, see "Safety" and "Prepare" chapters.

IMPORTANT: For more information on how to operate controls, see "Controls" chapter.

Set Up **124**

Operate **125**

Finish Job **127**

Set Up

IMPORTANT:

- When cutting asphalt, start trench in soil at edge of road and use shortest possible boom at full depth.
- Sight along center of hood to a stake driven beyond end of trench line for straight trench.
- For optimal spoils delivery, adjust the auger positions forward or backward to accommodate terrain and digging depth.

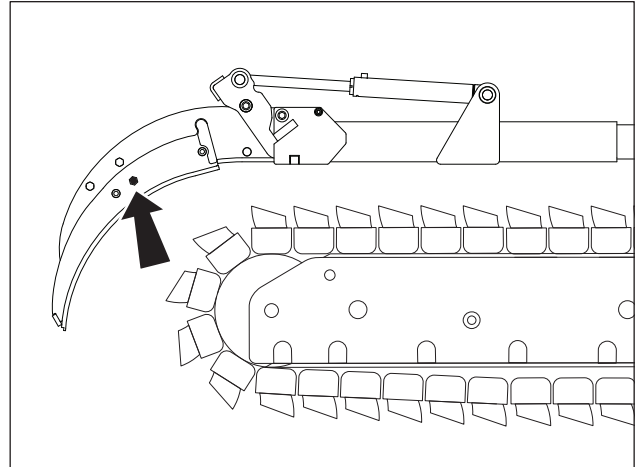

t33om080w.eps

1. If using optional trench cleaner, remove bolt installed for transport (shown).
2. Fasten and adjust seat belt.
3. Start machine.
4. Drive to starting point. Move in line with planned trench.
5. Set parking brake.
6. Select low ground drive speed.
7. Lower boom to just above ground.
8. Check that attachment speed/direction and ground drive controls are in neutral.
9. Lower backfill blade, if equipped, to reduce shock when trenching begins.

Operate

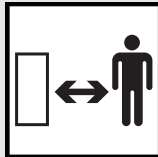
**⚠ WARNING**

Thrown objects. Impact can cause death or serious injury. Stay away.

To help avoid injury:

- Keep everyone at least 6' (1.8m) from machine, attachments, and their range of movement.
- Know soil conditions and adjust digging speed accordingly.

1. Select speed. DIGGING CHAIN WILL MOVE.

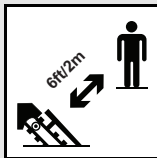
**⚠ DANGER**

Moving digging teeth. Contact will cause death or serious injury. Stay at least 6' (1.8m) away.

To help avoid injury:

- Allow 3' (0.91m) between digging teeth and obstacle. Machine may jerk when digging starts.
- Keep everyone at least 6' (1.8m) from machine, attachments, and their range of movement.
- Ensure parking brake is set.
- Trench cave-in or material caught in digging chain can result in contact with digging teeth.

2. Set to high throttle.
3. Lift trench cleaner, if equipped.
4. Slowly lower digging boom to desired trench depth.
5. Raise backfill blade, if equipped.
6. Release parking brake.

7. If using optional trench cleaner:

NOTICE:

- Do not have trench cleaner in working position when starting a trench.
- Do not back up with trench cleaner in working position.

Hydraulic

- Move forward about 1' (30cm), or until there is enough room for trench cleaner to enter trench.
 - Stop forward movement.
 - Raise boom slightly, then fully lower trench cleaner to lock it in place.
 - Lower boom to desired trench depth.
8. Set speed.

IMPORTANT:

- Ground drive speed/direction can be controlled with foot pedal or hand control. When trenching, set ground drive speed with hand control. Use foot pedal to temporarily adjust speed if digging conditions change for a short distance.
- Always start trenching with ground drive speed set to low.
- Increase ground drive speed only as soil conditions permit.

9. Operate engine at full throttle when working.

NOTICE:

- Do not make sharp turns. Lower boom to full depth when turning.
- If an object becomes lodged in chain, stop chain movement and raise boom slightly. Reverse chain direction. If object must be removed manually, turn engine off and set parking brake.

Finish Job

1. When trench is complete, stop forward movement.
2. Set to low throttle.
3. Raise boom.
4. As boom clears top of trench, stop chain movement.
5. If equipped with traversing trencher, return trencher to center position.
6. Raise trench cleaner, if equipped.
7. Drive a short distance away from work site.
8. Shut off machine.
9. Stow trench cleaner, if equipped.

Systems and Equipment

Chapter Contents



For additional precautions, see "Safety" and "Prepare" chapters.

Chain, Teeth, and Sprockets 130

- Chain and Tooth Maintenance 130
- Chain Type 130
- Chain Selection 131

Cruise Control 132

Optional Equipment 135

- Tractor 135
- Backhoe 135
- Microtrencher 136
- Plow 137
- Trencher 137

Counterweights 138

Chain, Teeth, and Sprockets

Chain and Tooth Maintenance

- Always replace sprockets at the same time as the digging chain. Sprockets and chain are designed to work together. Replacing one without the other will cause premature wear of the new part.
- Keep digging chain sharp. Using dull, worn teeth will decrease production and increase shock load to other trencher components. It can also cause chain stretch, which leads to premature wear and failure.
- Maintain proper amount of tension on digging chain. Overtightening will cause chain stretch and loss of machine performance. For correct tightening procedure, see "Maintenance" on page 143.
- Use tooth pattern most appropriate for digging conditions. If conditions change, contact your Ditch Witch® dealer for information about the most effective chain type and tooth pattern.

Chain Type

Chain Type	Features
2-pitch	More teeth for smoother cutting
4-pitch	Standard chain
Alternating side bar	Prevents soil compaction on chain
Bolt-on adapters	Allows easy configuration changes
Combination	Provides pick and shovel effect
Shark® Chain II	Versatile, little to no maintenance

Chain Selection

These charts are meant as a guideline only. No one chain type works well in all conditions. Contact your Ditch Witch® dealer for soil conditions and chain recommendations for your area. Ask for the latest Chain, Teeth, and Sprockets Parts Catalog.

- 1 = best
- 2 = better
- 3 = good
- 4 = not recommended

Soil	Description
Sandy soil	Sugar sand, blow sand, or other soils where sand is the predominant component
Soft soil	Sandy loam
Medium soil	Loams, loamy clays
Hard soil	Packed clays, gumbo, all compacted soils
Rocky soil	Chunk rock, glacial till, cobble, rip rap, gravel
Sticky soil	Gumbo, sticky clays

Chain	Sandy Soil	Soft Soil	Medium Soil	Hard Soil	Rocky Soil	Sticky Soil
2-pitch cup tooth	2	3	1	1	3	4
4-pitch cup tooth	3	1	2	3	4	1
Alternating side bar	4	4	4	4	4	1
Bolt-on adapter, 2-pitch	4	4	3	2	1	4
Bolt-on adapter, cup tooth combo	4	3	2	1	2	4
Shark® Chain II	4	3	2	1	1	4

Cruise Control

EMERGENCY SHUTDOWN: Turn ignition switch off.

IMPORTANT: See "Controls" on page 27.

Cruise control is a standard feature that allows machine to automatically adjust ground drive speed according to digging conditions. In easier soil conditions, ground drive speed will increase. When machine encounters difficult soil conditions, ground drive speed will decrease.

IMPORTANT: When cruise control is active, ground drive system is interlocked with attachment.

- Ground drive will not begin moving if attachment is not moving.
- Ground drive will stop if operator stops attachment. If attachment is restarted, ground drive will restart, as long as ground drive control is in forward position.
- If ground drive is stopped for more than 15 seconds due to attachment being stopped, operator must set ground drive control to neutral before it can be used again.
- Attachment interlock does not apply to plow attachments.

Microtrenching

1. Ensure ground drive is in neutral.
2. Ensure ground drive is set to low.
3. Ensure cruise control is off.
4. Set cruise control dial to 2350 RPM or higher.
5. Turn cruise control on.
6. Following procedures in "Microtrench" on page 103, begin trenching to desired depth.
7. When desired depth is reached, set to high throttle.
8. Slowly drive forward.
9. Slowly adjust cruise control speed dial to match digging conditions.
10. When finished microtrenching, return controls to neutral.
11. Turn cruise control off.
12. Allow chain to dig itself free before stopping attachment.

Trenching

1. Ensure ground drive is in neutral.
2. Ensure ground drive is set to low.
3. Ensure cruise control is off.
4. Set cruise control dial to middle position.
5. Turn cruise control on.
6. Following procedures in "Trench" on page 123, begin trenching to desired depth.
7. When desired depth is reached, set to high throttle.
8. Slowly drive forward.
9. Slowly adjust cruise control speed dial to match digging conditions.
10. When finished trenching, return controls to neutral.
11. Turn cruise control off.
12. Allow chain to dig itself free before stopping attachment.

Anti-Stall Technology

RT70 tractors equipped with trenchers include Anti-Stall Technology (AST) as part of cruise control. AST will detect impending stall conditions, and will attempt to prevent engine from stalling during trenching.

AST can be turned on in the main menu. See "Main Menu" on page 65.

1. Ensure that Anti-Stall Technology is turned on.
2. Ensure ground drive is in neutral.
3. Ensure ground drive is set to low.
4. Ensure cruise control is off.
5. Set cruise control dial to middle position.
6. Turn cruise control on. AST icon will turn green to indicate AST is active. See "Gauges and Indicators" on page 59.
7. Following procedures in "Trench" on page 123, begin trenching to desired depth.
8. When desired depth is reached, set to high throttle.
9. Set engine to full throttle.
10. Slowly drive forward.

Cruise Control

11. If AST icon turns yellow, trencher and ground drive will stop while system waits for operator response. System will wait up to ten seconds for operator response before aborting process.
 - Press AST switch within 10 seconds to activate system. See "Console, Right" on page 52.
 - AST system will automatically control trencher and ground drive during attempts to free obstruction.
 - System will make multiple attempts to free obstruction.
 - AST icon will remain yellow during process.
 - AST icon will return to green if process is successful, and trenching can continue as normal.
 - AST icon will turn red if process fails, or if AST switch is not pressed.
12. If AST icon turns red, trencher and ground drive will stop.
 - Ground drive and trencher must be set to neutral before system will allow operation to continue.
 - Operator may have to manually control boom and ground drive to clear chain of obstruction.
13. When finished trenching, return controls to neutral.
14. Turn cruise control off.
15. Allow chain to dig itself free before stopping attachment.

Plowing

1. Ensure ground drive is in neutral.
2. Ensure ground drive is set to low.
3. Ensure cruise control is off.
4. Set ground drive to maximum speed suitable for digging conditions.
5. Turn cruise control on.
6. Slowly adjust cruise control speed dial control to match digging conditions.
7. When finished plowing, return controls to neutral.
8. Turn cruise control off.

Optional Equipment

Contact your Ditch Witch® dealer for more information about the following optional equipment.

Tractor

Equipment	Description
Anti-stall technology	Automated stall reduction.
Backfill blade	Allows jobsite restoration; backfill blade tilt kit also available.
Backup alarm	Alarm sounds when tractor is in reverse.
Canopy	Protection from sun and precipitation.
Flasher light kit	Mounts to ROPS.
GPS	Allows tracking of position.
Hydraulic manifold kit	Allows hydraulically-driven attachments to be connected.
Lights with front weights	Adds light to front weight kit.
Lights with reel carrier	Adds light to reel carrier.
SMV sign mount	Adds mounting point for slow moving vehicle (SMV) sign.
Super Rear Steer	Allows additional automatic steering modes.
Tires/Tracks	Can be equipped with tires or tracks.
Trench depth meter	Displays trenching depth and travel speed.
Work light kit	Mounts to ROPS.

Backhoe

Equipment	Description
Bucket width	12-24" (305-610mm) buckets available
Light kit	Adds work lights to backhoe.

Microtrencher

Equipment	Description
Bits and bit holders	Replace as needed to increase efficiency and keep from damaging machine.
Blades	Provides options for cutting trenches 0.75" (19mm), 0.95" (24mm), or 1.25" (32mm) wide.
Chute kit	Allows spoils to be directed.
Vacuum hose kit	Connects vacuum hose on trencher to hose on vacuum excavation machine; includes hose guides that mount to side of trencher.

Plow

Equipment	Description
Blades	Several blade options are available
Cable guide	Designed to fit Ditch Witch machines and speed cable installation
Reel carrier	Designed to fit Ditch Witch equipment and speed cable installation
Reel winder	Rotates reel carrier spool
Tape dispenser	For marking tapes

Trencher

Equipment	Description
Booms	Several boom length options available
Long auger extensions	For conditions that require spoils to be moved farther from the trench
Trench cleaner	Hydraulic cleaner, removes spoils from the trench floor

Counterweights

General counterweighting values are shown below. For specific counterweighting requirements, contact your Ditch Witch dealer.

Multiple attachment configurations may require additional tire options. See "Tire Fill" on page 139..

CT70/ST70

		Front Attachment		
		Weight Rack	BH70	RC20
Tires	Front weight	●	□	□
	Rear weight	□	□	□
Quad	Front weight	●	□	□
	Rear weight	□	□	□

●	Counterweights required
□	Counterweights not required

MT12/MT16

		Front Attachment		
		Weight Rack	BH70	RC20
Tires	Front weight	●	□	□
	Rear weight	□	●	●
Quad	Front weight	●	□	□
	Rear weight	□	□	□

●	Counterweights required
□	Counterweights not required

VP70

		Front Attachment		
		Weight Rack	BH70	RC20
Tires	Front weight	●	□	□
	Rear weight	●	□	□
Quad	Front weight	●	□	□
	Rear weight	○	○	○

●	Counterweights required
○	Counterweights recommended for performance
□	Counterweights not required

Tire Fill

			Rear Attachment				
			CT70	MT12	MT16	ST70	VP70
Front Attachment	Weight Rack	Front tires	○	◆	◆	○	●
		Rear tires	○	◆	◆	○	●
	RC20	Front tires	●	◆	◆	●	●
		Rear tires	□	◆	◆	□	●
	BH70	Front tires	●	◆	◆	●	●
		Rear tires	□	◆	◆	□	●

●	Urethane fill
◆	Solid tires or urethane fill
○	Urethane fill recommended for performance
□	Fill not required

Complete the Job

Chapter Contents



For additional precautions, see "Safety" and "Prepare" chapters.

Restore Jobsite 142

Rinse Equipment 142

Stow Tools 142

Restore Jobsite

After product is installed, return spoils to the trench with optional backfill blade.

1. Position machine at end of trench, several feet from spoils. Aim tractor at outer edge of spoils.
2. Adjust backfill blade to fit land contour.
3. Move outer edge of spoils toward trench. Take two or more passes at spoils rather than moving all spoils at once.
4. Repeat on other side of trench, if needed.
5. Engage float and make final pass over trench.

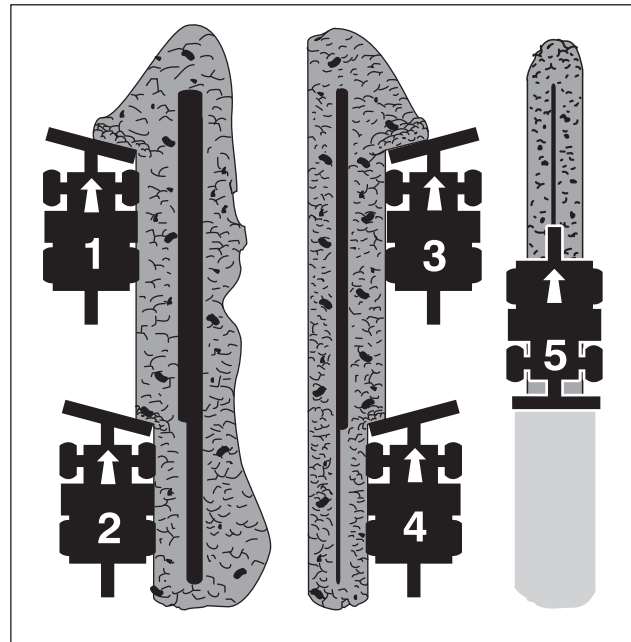

Backfilling.eps

Rinse Equipment

NOTICE:

- Never spray water onto operator's console or electrical center in engine compartment. Water can damage electrical components. Wipe down instead.
- Ensure all mud and debris is rinsed from operator's station floor.
- Ensure all mud and debris is rinsed from tracks before parking overnight.

Spray water onto equipment to remove dirt and mud.

Stow Tools

Ensure tools and accessories are loaded and properly secured on trailer or truck.

Maintenance

Chapter Contents

 For additional precautions, see "Safety" and "Prepare" chapters.

IMPORTANT: For more information on how to operate controls, see "Controls" chapter.

Maintenance Precautions 145

- Welding Precaution 146
- Washing Precaution 146
- Changing Attachments 146
- Switching Between Tracks and Tires 146

Recommended Lubricants 147

- Engine Oil Temperature Chart 148
- Approved Coolant 148
- Approved Fuel 149

Tractor Service Interval Chart 150

Tractor Procedures 151

Backhoe Maintenance Interval Chart 169

Backhoe Procedures 169

Microtrencher Maintenance Interval Chart 170

Microtrencher Procedures 170

Plow Maintenance Interval Chart 176

Plow Procedures 177

Trencher Maintenance Interval Chart 183

Trencher Procedures 184

Maintenance Precautions



⚠ WARNING Jobsite hazards. Exposure can cause death or serious injury. Use correct equipment and work methods. Use and maintain appropriate safety equipment.

To help avoid injury:

- Wear personal protective equipment including hard hat, safety eye wear, foot protection, hearing protection, and gloves (except when near rotating equipment).
- Remove jewelry.
- Wear close-fitting, high visibility clothing.
- Have other personal protective equipment, such as insulated boots and gloves, breathing protection, and face shield, etc. available for use depending on jobsite hazards or requirements.

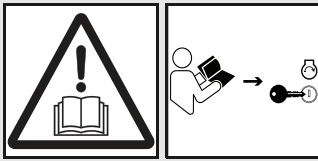

⚠ WARNING Misuse of machine can cause death or serious injury. Read and understand operator's manual and all other safety instructions before use. Know how to use all controls.

To help avoid injury:

- Unless otherwise instructed, all service should be performed with the engine off and cool.
- Lower unsecured, raised components before servicing equipment.
- Unless otherwise instructed, all service should be performed with machine parked on level surface.
- Refer to US Occupational Safety and Health Administration (OSHA) guidelines for appropriate lockout-tagout procedures.

Welding Precaution

NOTICE: Welding can damage electronics.

- Welding currents can damage electronic components. Always disconnect the ECU ground connection from the frame, harness connections to the ECU, and other electronic components prior to welding on machine or attachments.
- Connect welder ground close to welding point and make sure no electronic components are in the ground path.
- Failure to disconnect battery will cause damage to battery.

Washing Precaution

NOTICE: Water can damage electronics. When cleaning equipment, do not spray electrical components with water.







Changing Attachments

This machine is programmed to operate with the original attachment configuration. If you change attachments, contact your Ditch Witch dealer to ensure the electronic programming is updated. If you change attachments without updating the electronic programming, your attachment may not function correctly.

Switching Between Tracks and Tires

The RT70 machine can be equipped with tires or tracks. Contact your Ditch Witch dealer to switch between tracks and tires. Your dealer will adjust steering stop settings to match whether the machine is on tracks or tires.

Recommended Lubricants

Item	Description
 DEAC	Diesel engine antifreeze/coolant, low silicate, fully-formulated meeting ASTM D6210 See "Approved Coolant" on page 148.
 DEO	Diesel engine oil meeting or exceeding API service classification CJ-4, ACEA E6, or JASO DH-2. Engine must use low sulfated ash, phosphorous, and sulfur (low SAPs) oil. See viscosity chart. API American Petroleum Institute, ACEA European Automobile Manufacturer's Association
 EPG	Extreme pressure grease, polyurea based NLGI GC-LB Grade 1.5 or lithium based NLGI GC-LB Grade 2, with extreme pressure additives
 MPG	Multipurpose grease, polyurea based NLGI GC-LB Grade 1.5 or lithium based NLGI GC-LB Grade 2
 MPL	Multipurpose gear oil meeting API service classification GL-5 (SAE 80W90)
 THF	Tractor hydraulic fluid, Phillips 66® PowerTran XP, Mobilfluid® 423, Chevron® Tractor Hydraulic Fluid, Texaco® TDH Oil, or equivalent

Proper lubrication and maintenance protects Ditch Witch equipment from damage and failure. Service intervals listed are for minimum requirements. In extreme conditions, service machine more frequently. Use only genuine Ditch Witch parts, filters, approved lubricants, TJC, and approved coolants to maintain warranty. Fill to capacities listed in "Fluid Capacities" on page 203.

For more information on engine lubrication and maintenance, see your engine manual.

Engine Oil Temperature Chart

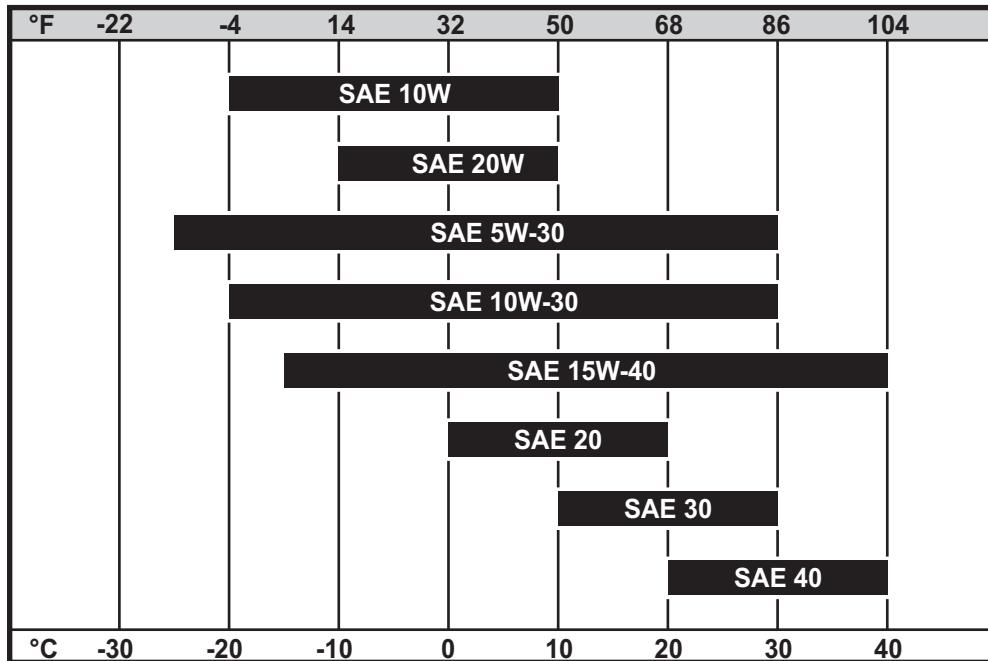

t63om095h21.eps

Temperature range anticipated before next oil change

Approved Coolant

NOTICE:

- Use only pre-diluted coolant or concentrated coolant mixed with distilled water. Do not use tap water.
- Using water or high-silicate automotive-type coolant will lead to engine damage or premature engine failure.
- Mixing heavy-duty diesel engine coolant and automotive-type coolants will lead to coolant breakdown and engine damage.

This machine was filled with coolant meeting ASTM D6210 before shipment from factory. Add or replace only with coolant meeting this specification. This coolant is available, pre-diluted, from your Ditch Witch dealer as part number 255-1055.

Approved Fuel

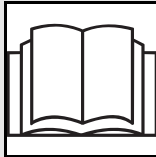
**⚠ WARNING**

Ultra Low Sulfur Diesel (ULSD) poses a greater static ignition hazard than earlier diesel formulations with higher sulfur content. Avoid death or serious injury from fire or explosion; consult with your fuel or fuel system supplier to ensure the delivery system is in compliance with fueling standards for proper grounding and bonding practices.

This engine is designed to run on diesel fuel. Use only high quality fuel meeting ASTM D975 No. 2D, EN590, or equivalent. At temperatures below 32°F (0°C) winter fuel blends are acceptable. See the engine operation manual for more information.

NOTICE: Use only Ultra Low Sulfur Diesel (less than 15ppm sulfur content in the US and Canada or 10mg/kg in EU and Japan) in this machine. Operating with higher sulfur content will damage the engine and aftertreatment device.

Biodiesel blends up to 5% (B5) are approved for use in this machine. The fuel must meet the specifications for diesel fuel shown above. In certain markets, higher blends may be used if certain steps are taken. Extra attention is needed when using biodiesel, especially when operating in cold weather or storing fuel. Contact your Ditch Witch dealer or the engine manufacturer for more information.

Tractor Maintenance Interval Chart

IMPORTANT: Chart indicates first instance of repeated service procedures. See detailed information below.

▽	Adjust, service, or test	□	Change, initial	○	Lube, initial
▲	Check	■	Change	●	Lube

Service	Before Startup	10 Hours	50 Hours	100 Hours	200 Hours	500 Hours	1000 Hours	2000 Hours	As Needed
Axle spindle pins					●				
Axle trunion mounts					●				
Battery		▲							▽
Belt, engine drive			▲					■	
Coolant		▲				▽		■	
Dust ejector valve		▲							
Engine compartment		▲							
Filter, air	▲								■
Filter, engine oil (see Oil, engine)									
Filter, fuel		▲				■			
Filter, hydraulic (see Fluid, hydraulic)					□	■			
Fluid, hydraulic		▲				□	■		
Hydraulic hoses	▲	▲							
Oil, differential					▲		■		
Oil, engine		▲				■			
Oil, ground drive gearbox				▲			■		
Oil, planetary wheel ends					▲		■		

Service	Before Startup	10 Hours	50 Hours	100 Hours	200 Hours	500 Hours	1000 Hours	2000 Hours	As Needed
Parking brake									▽
Radiator		▲							▽
Seat belt								▲	
Tires	▲								
Track hub bolts				▲					
Track pivot bearings			●						
Track rollers and sprocket				▲					
Track tension				▲					▽
Universal joints			○		●				
Water separator	▲								

Tractor Procedures

Axle Spindle Pins

Lube at zerk (shown) with EPG every 250 hours.

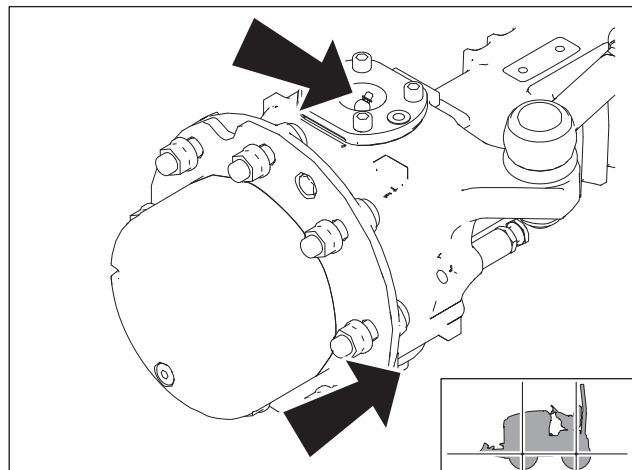

t63om027h21.eps

Battery



⚠ WARNING Corrosive fluid. Contact can cause death or serious injury. Avoid contact. Wear appropriate gloves. See Safety Data Sheet (SDS) for more information.

To help avoid injury:

- Never attempt to charge a battery that is leaking, bulging, heavily corroded, frozen, or otherwise damaged.
- Refer to Safety Data Sheet (SDS) for additional information regarding battery.



⚠ WARNING Explosive hydrogen gas. Fire or explosion can cause death or serious injury. Keep heat flames, sparks, and other sources of ignition away.

To help avoid injury:

- Use a single 12V maximum source for charging. Never connect to rapid chargers or dual batteries.
- Never lean over battery when making connections.
- Never allow vehicles to touch when charging.
- Never short-circuit battery terminals for any reason or strike battery posts or cable terminals.
- Refer to Safety Data Sheet (SDS) for additional information regarding battery.

NOTICE:

- Electronic components can be easily damaged by electrical surges. Jump starting can damage electronics and electrical systems, and is not recommended. Try to charge the battery instead. Use quality large diameter jumper cables capable of carrying high currents (400 amps or more). Low quality cables may not allow enough current flow to charge a dead/discharged battery.
- Read all steps thoroughly and review illustration before performing procedure.

Check every 10 hours. Charge as needed.

Check

1. Turn battery disconnect switch, if equipped, off.
2. Ensure no ignition sources are near battery.
3. Loosen and remove battery cable clamps carefully, negative (-) cable first.
4. Clean cable clamps and terminals to remove dull glaze.
5. Check for signs of internal corrosion in cables.
6. Connect battery cable clamps, positive (+) cable first.
7. Tighten any loose connections.
8. Ensure battery tiedowns are secure.
9. Turn battery disconnect, if equipped, on.

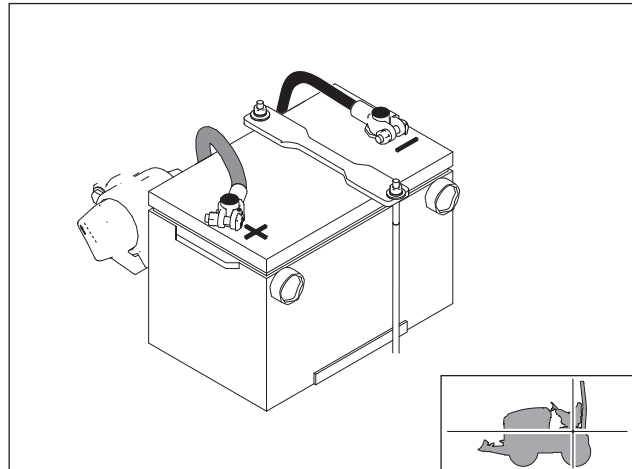

t630m028h21.eps

Charge

1. Park service vehicle close to disabled machine but do not allow vehicles to touch.
2. Set parking brake in both, if equipped.
3. Turn ignition switch off in both vehicles and turn off all electrical loads.
4. Disconnect machine controller.
5. Inspect battery in disabled machine (B) for signs of cracking, bulging, leaking, or other damage.
6. Connect red positive (+) jumper cable clamp to positive (+) post of battery (A) in disabled machine.

IMPORTANT: Some machines may have a positive jumper cable terminal (1) located externally. If so equipped, connect red positive (+) jumper cable clamp to terminal.

7. Connect the other red positive (+) jumper cable clamp to positive (+) post of battery (A) in service vehicle.
8. Connect black negative (-) cable clamp to negative (-) post of battery (A) in service vehicle.
9. Connect the other black negative (-) cable clamp to engine or frame ground on disabled vehicle, at least 12" (305 mm) from failed battery, as shown.
10. Operate service vehicle engine at 1500-2000 rpm for a few minutes to build an electrical charge in failed battery.
11. Stop engine in service vehicle.
12. Remove jumper cables from service vehicle, black negative (-) clamp first. Do not allow clamps to touch.
13. Remove black negative (-) cable clamp from disabled engine or frame ground.
14. Remove red positive (+) cable clamp from disabled machine.
15. Reconnect machine controller.
16. Start disabled machines.

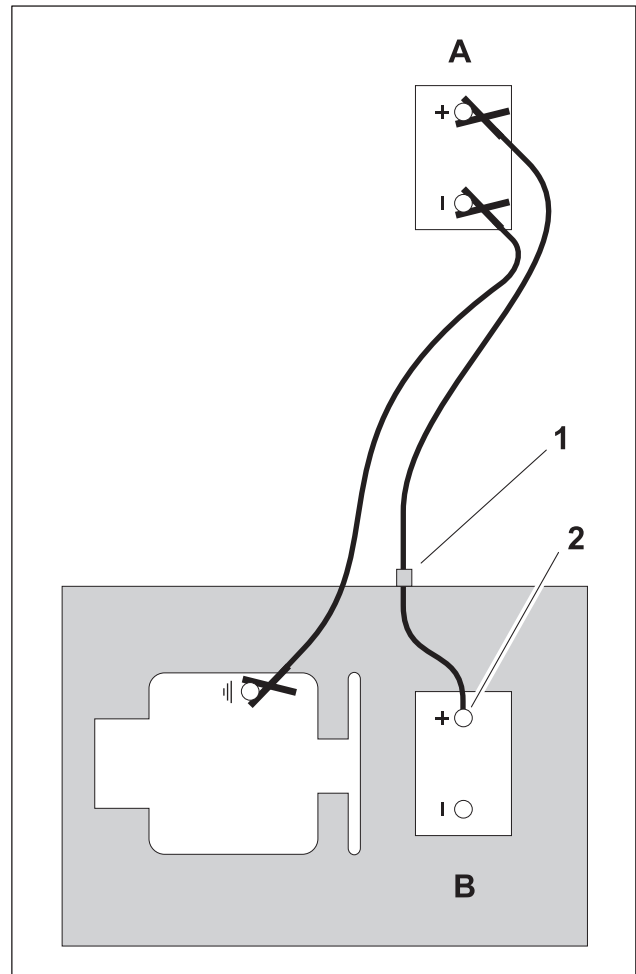

Battery_Jumpstart_B.eps

Belt, Engine Drive

Check every 50 hours. Change every 2000 hours.

Check

Check belt for cracks and wear. If damaged, change belt.

Change

1. Rotate fan idler (Shown) to relieve belt tension.
2. Replace belt.
3. Slowly return tensioner to normal operating position.

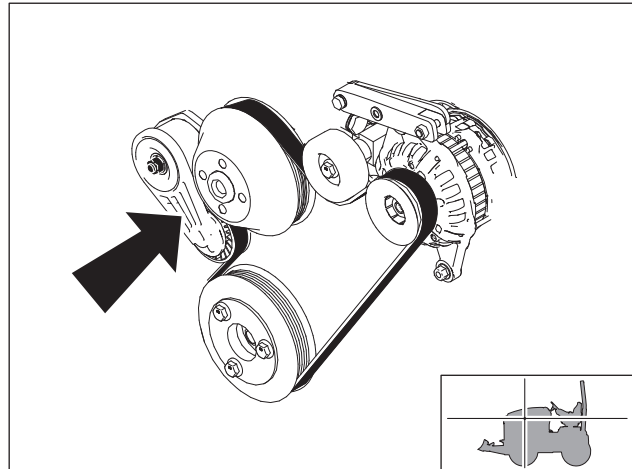

t63om029h21.eps

NOTICE: Spring loaded tensioner maintains tension on belt. Periodically check that tensioner arm is not bottomed out against stop or showing signs of wear.

Coolant

Check every 10 hours. Test freeze protection level every 500 hours. Adjust as needed. Change every 2000 hours.

Check Level

1. Check level at fill (1).
2. Add DEAC at fill as needed to keep level at bottom of fill neck.

Test

Use hydrometer or refractometer to test coolant freeze protection level. Recommended freeze protection level is -34°F (-37°C).

If colder temperatures are expected, consult your Ditch Witch dealer or coolant supplier.

Use pre-diluted coolant to maintain proper freeze protection.

Change

1. Remove plug (2) to drain.
2. Install plug.
3. Add DEAC at fill to keep level visible at sight glass.

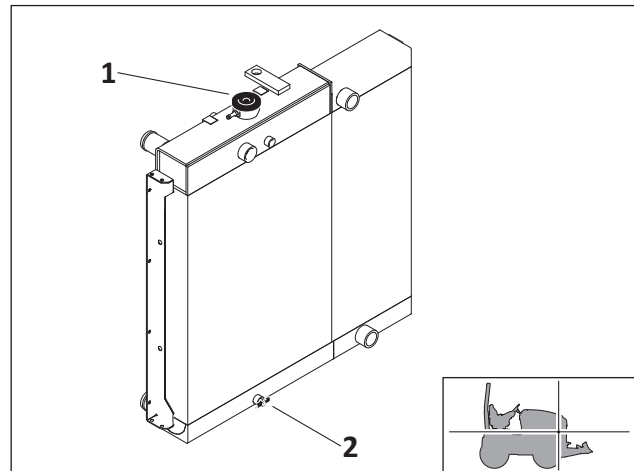

t630m030h21.eps

Dust Ejector Valve

Check valve (shown) every 10 hours. Ensure valve is not inverted, damaged, plugged, or cracked.

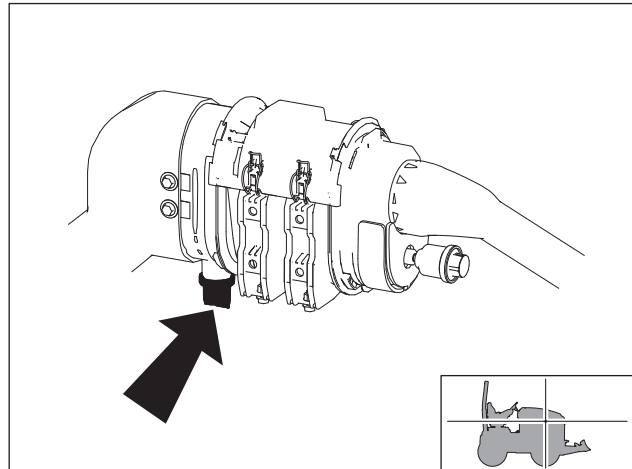

t63om031h21.eps

Engine Compartment

NOTICE:

- Check more often if operating in large brush, grassy conditions, or if machine is being stored.
- Do not use water or compressed air to remove debris.

Check casing below fan (shown) for debris, mud, water, and ice buildup every 10 hours and after long-term storage.

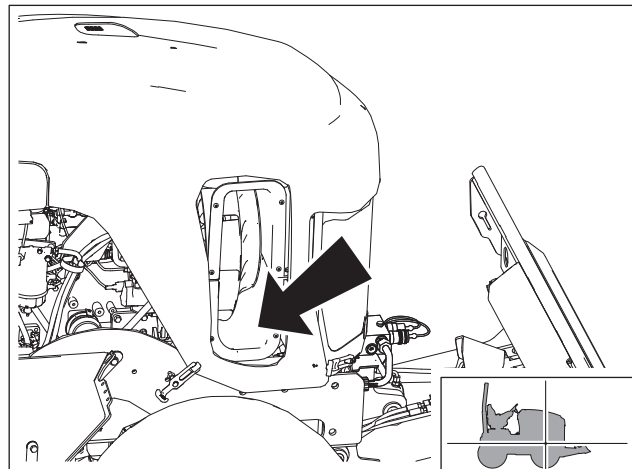

t63om032h21.eps

Manually clean out debris as needed.

Filter, Air

NOTICE:

- Only open the air filter canister when air filter service indicator shows that service is needed.
- Change the elements. Do not attempt to clean them.
- Improperly installed primary element can lead to premature engine failure.
- Cleaning with compressed air or water can damage filter elements.
- Tapping filter elements to loosen dirt can damage filter elements.

Check before startup and every 10 hours. Change as needed.

Check

Check air filter service indicator (3). Change filter when red band on indicator is visible.

Change

1. Remove cover.
2. Remove primary element (1).
3. Remove secondary element every third change of primary element.
4. Wipe inside of housing and wash cover.
5. Insert secondary element, if required, and ensure it is seated correctly.
6. Insert new primary element.
7. Reinstall cover.
8. Reset air filter service indicator.

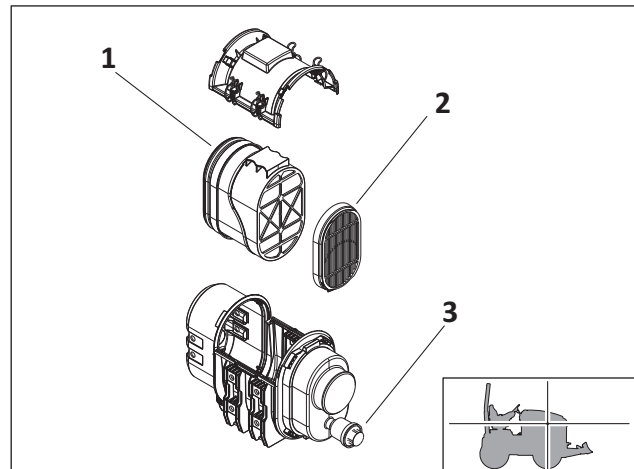

t63om033h21.eps

Filter, Fuel

Check filters (1,2) every 10 hours. Change every 500 hours.

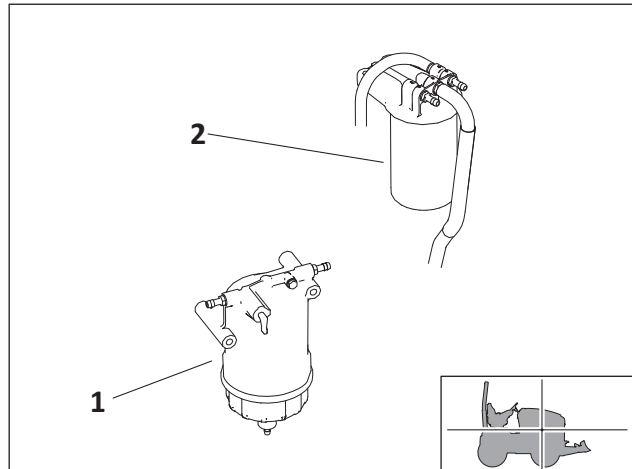

t63om034h21.eps

Fluid, Hydraulic

NOTICE: Change every 500 hours if jobsite temperature 100°F (38°C) more than 50% of the time, or if jobsite is extremely dusty.

Fluid

Check every 10 hours.

Initial hydraulic fluid change at 500 hours.

Normal hydraulic fluid change every 1000 hours.

Filter

Initial hydraulic filter change at 200 to 250 hours, or when necessary.

Normal hydraulic filter changes every 500 hours.

Check

1. Check level at sight glass (4).
2. Add THF at fill (3) as needed to keep level at halfway point on sight glass.

Change

1. Remove plug (1) to drain.
2. Install plug.
3. Change filter (2) if necessary.
4. Add THF at fill to keep level at halfway point on sight glass.

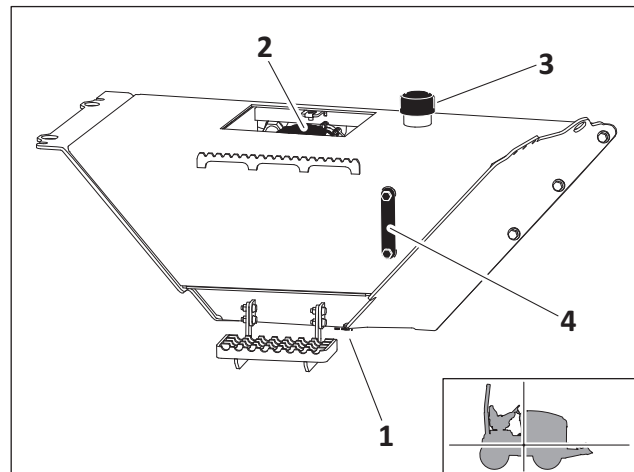

t63om035h21.eps

NOTICE: Filter is inside hydraulic tank.

Hydraulic Hoses



⚠ WARNING Pressurized fluid or air. Injection can cause death or serious injury. Refer to operator's manual for correct use.

To help avoid injury:

- Use a piece of cardboard or wood, rather than hands, to check for leaks.
- Before disconnecting a hydraulic line, turn engine off and operate all controls to relieve pressure.
- Lower, block, or support any raised component with a hoist.
- Cover connection with heavy cloth and loosen connector nut slightly to relieve residual pressure. Catch all fluid in a container.
- Before using system, check that all connections are tight and all lines are undamaged.
- If you are injured, seek immediate medical attention from a doctor familiar with this type of injury.

Check for leaks where shown before startup and every 10 hours.

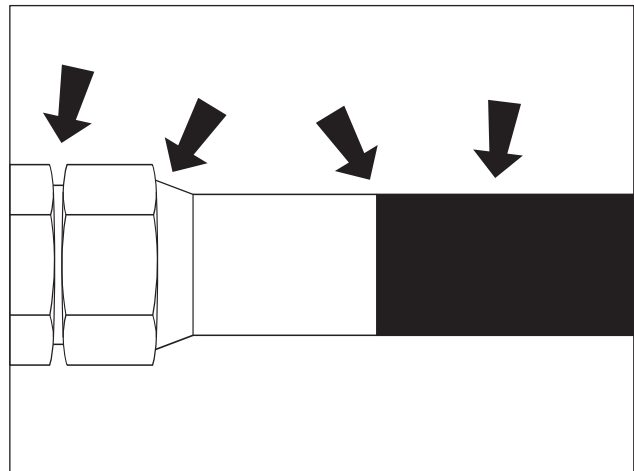

CheckHoses.eps

Oil, Differential

Check every 250 hours. Change every 1000 hours.

Check

1. Check level at fill (1).
2. Add MPL at fill as needed to keep level visible.

Change

1. Remove plugs (2) to drain.
2. Install plug.
3. Add MPL at fill to keep level visible.

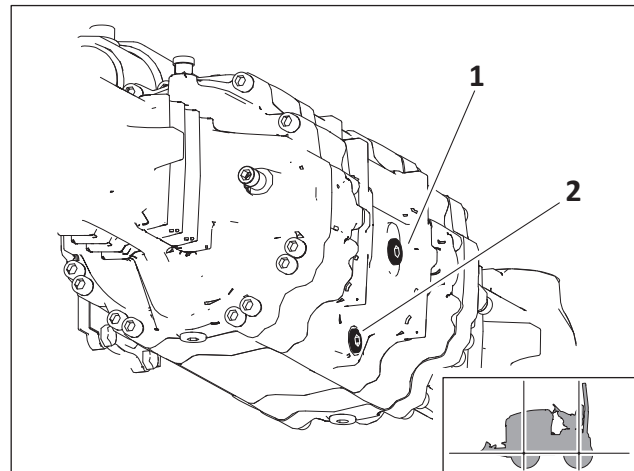

t63om036h21.eps

Oil, Engine

Check every 10 hours. Change after 250 hours and every 500 hours thereafter.

Check

1. While oil is warm, check level at dipstick (4).
2. Add DEO at fill (2) as needed to keep level at highest line on dipstick.

Change

1. While oil is warm, remove plug on drain (3) to drain.
2. Install plug.
3. Remove filter (1) and replace with new filter.
4. Add DEO at fill to keep level at highest line on dipstick.

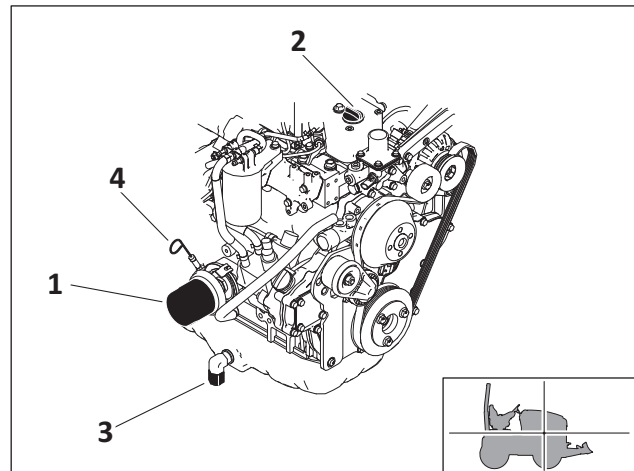

t63om037h21.eps

Oil, Ground Drive Gearbox

Check every 250 hours. Change every 1000 hours.

Check

1. Check level at fill (1).
2. Add MPL at fill as needed to keep level at raised horizontal line on gearbox.

Change

1. Remove plug (2) to drain.
2. Install plug.
3. Add MPL at fill until level is at raised horizontal line on gearbox.

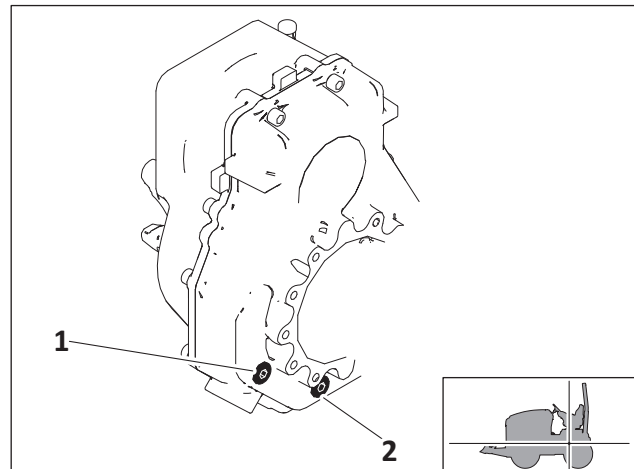

t630m038h21.eps

Oil, Planetary Wheel End

Check every 250 hours. Change every 1000 hours.

Check

1. Position wheel with plug at midway position (A).
2. Remove tire or track.
3. Check that level is visible at plug.
4. Add MPL at plug as needed to keep level visible at plug.

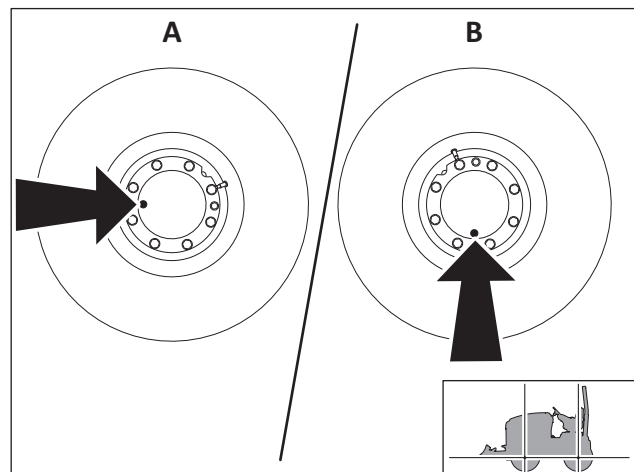

t630m039h21.eps

Change

1. Position wheel with plug at bottom (B).
2. Remove tire or track.
3. Remove plug to drain oil.
4. Reposition wheel with plug at midway position.
5. Add MPL at plug to keep level visible at plug.
6. Install plug.
7. Install tire or track.

Parking Brake, Mechanical Release

Release

1. Remove four brake release bolts (shown) on rear axle.
2. Remove spacers from bolts, set spacers aside.
3. Reinstall four bolts until finger tight.
4. Tighten bolts on left side.
 - Tighten left front bolt 30°.
 - Tighten left rear bolt 30°.
 - Repeat until brake releases.

NOTICE: It is not necessary to fully tighten bolts.

5. Repeat step 4 on right side.

Engage

1. Loosen bolts on left side.
 - Loosen left front bolt 30°.
 - Loosen left rear bolt 30°.
 - Repeat until brake engages.
2. Repeat step 1 on right side.
3. Remove bolts.
4. Reinstall bolts with spacers.
5. Tighten.

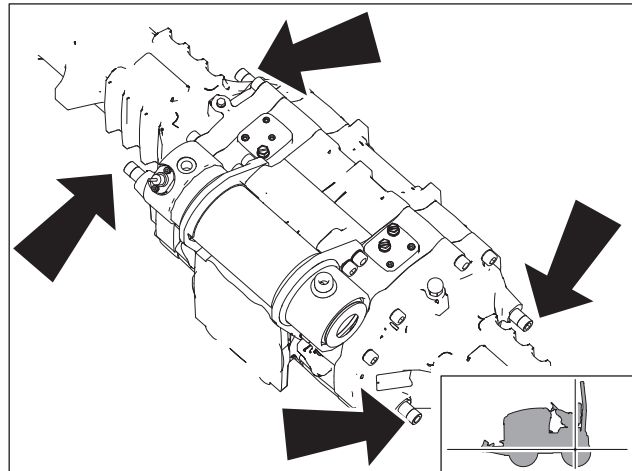

t63om094h21.eps

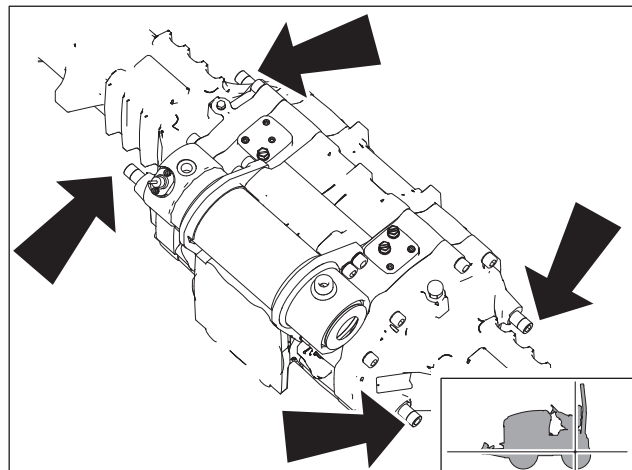

t63om094h21.eps

Radiator

NOTICE: Radiator may need to be cleaned more frequently in dusty or grassy conditions.

Check every 10 hours. Clean as needed.

Check

Check radiator (shown) for dirt, grass, and other debris.

Clean

1. Clean fins with compressed air or spray wash.

NOTICE: Do not damage fins with high-pressure air or water.

2. Remove plates on right side of machine and spray through radiator toward exterior.
3. If grease and oil are present on radiator, spray with solvent and allow to soak overnight.

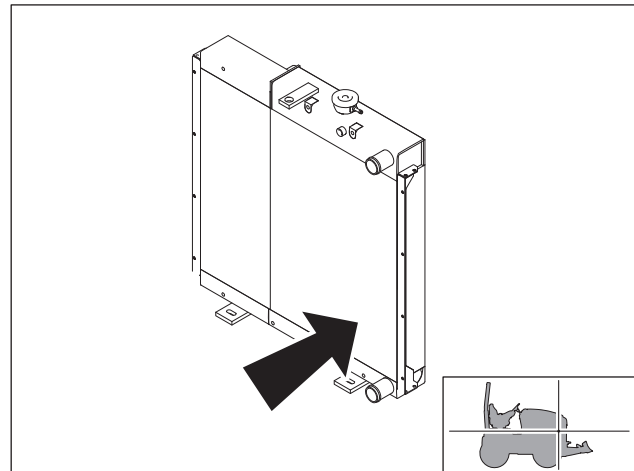

t63om040h21.eps

Seat Belt

Check every 2000 hours. Replace any worn or damaged components.

Buckle and Latch

Check that buckle and latch (1) are not broken or corroded. When inserting the latch into the buckle, the latch should insert smoothly until an audible click is heard. Latch should not release when the seat belt is tugged.

Webbing

Check seat belt webbing (2) to ensure that it is not cut, frayed, or showing signs of extreme or unusual wear. Check the area near the buckle and latch and anywhere the seat belt has contact with equipment or seat.

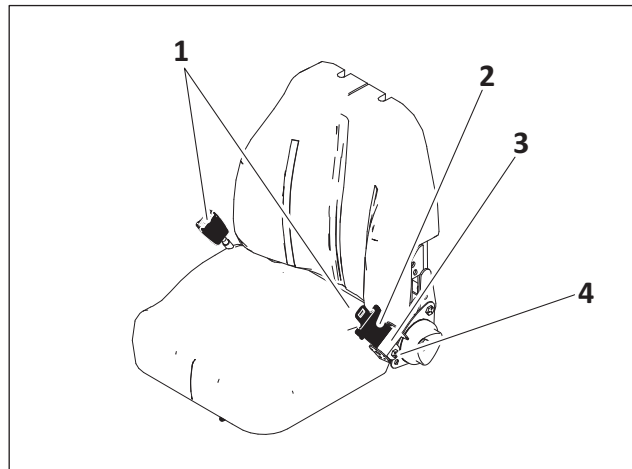

t63om041h21.eps

Retractor

Check that the retractor (3) operates smoothly when the belt is pulled and released. Retractor should spool belt without locking.

Mounting Hardware

Check the seat belt mounting hardware (4) on both sides of the seat to ensure it is tight. Replace missing, damaged, or corroded bolts.

Tires

Check pressure (1) before each use and every 10 hours. Inflate as indicated below:

- 19.0/45-17 tire: 50psi (3.5bar)

Check lug nuts (2) and tighten to 295ft•lb (400N•m).

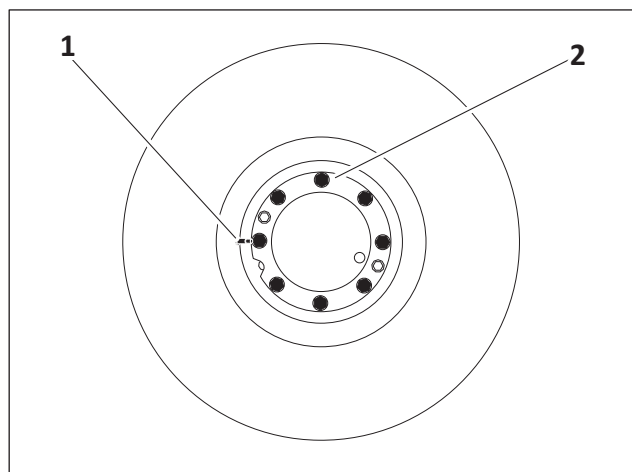

t63om042h21.eps

Track Hub Bolts

Check every 100 hours. Tighten to 295ft•lb (400N•m) as needed.

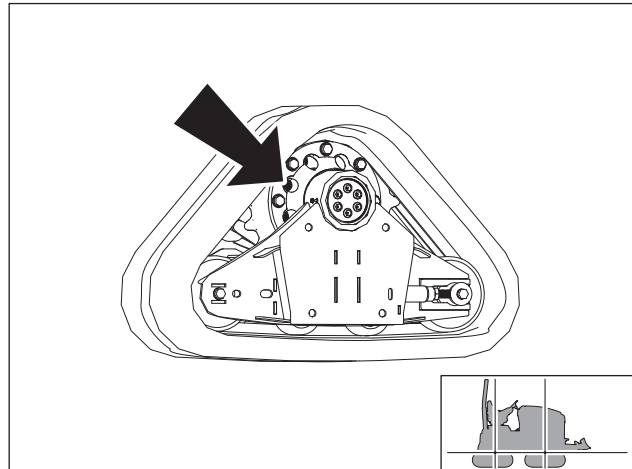

t63om043h21.eps

Track Pivot Bearings

Lube at zerk (shown) with MPG every 50 hours.

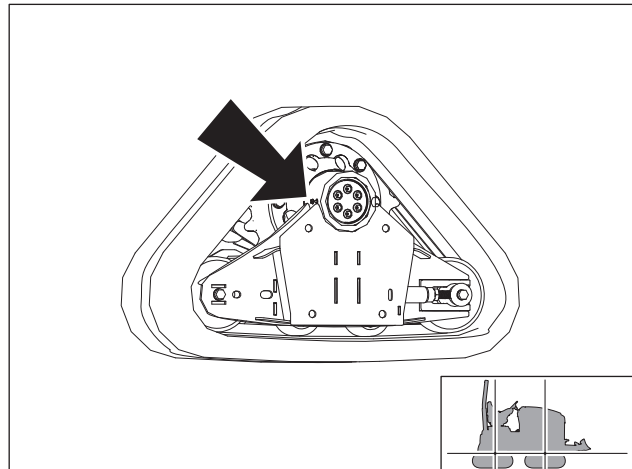

t63om044h21.eps

Track Rollers and Sprocket

Check rollers and sprocket (shown) every 100 hours. Replace as needed.

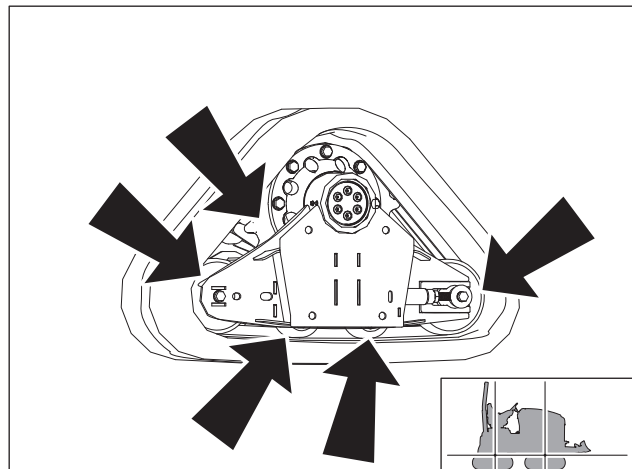

t63om045h21.eps

Track Tension

Check every 100 hours. Adjust as needed.

Check

If red shows in window (3), adjust track belt.

Adjust

1. Loosen jamb nut on each side of roller (1).
2. Turn adjustment nut (2) until no red is visible in adjustment window.
3. Tighten jamb nuts.

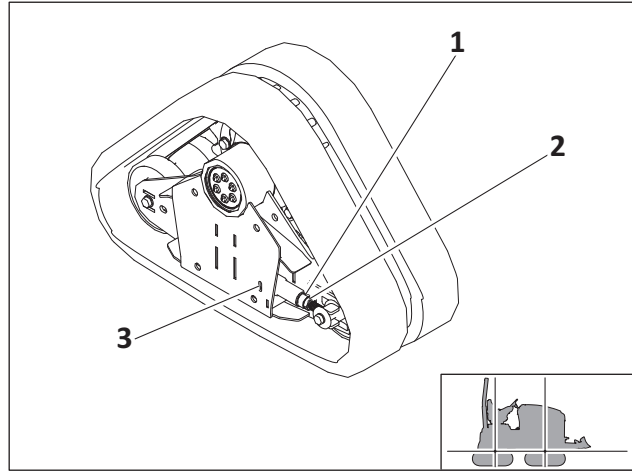

t63om046h21.eps

Universal Joints

Lube joints (shown) at zerks with MPG after 50 hours and every 250 hours thereafter.

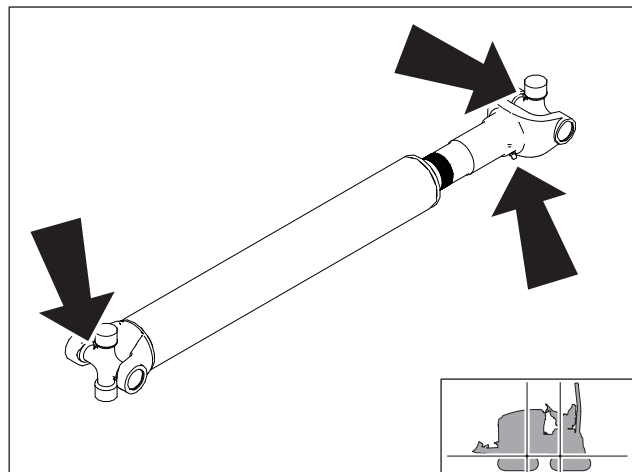

t63om047h21.eps

Water Separator

Check water separator (shown) located on fuel filter before startup and every 10 hours. Drain water as needed until fuel runs from drain.

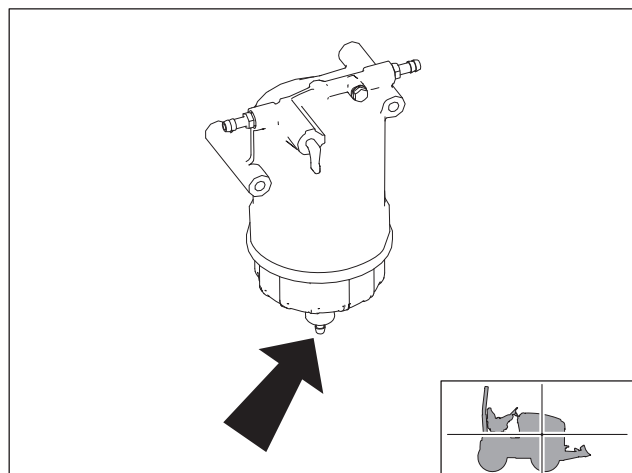

t63om048h21.eps

Backhoe Service Interval Chart*

▽	Adjust, service, or test	□	Change, initial	○	Lube, initial
▲	Check	■	Change	●	Lube

Service	10 Hours	50 Hours	100 Hours	250 Hours	500 Hours	1000 Hours	2000 Hours	As Needed
Pins and bushings								■

*The chart above indicates the first instance of repeated service procedures. See detailed information below.

Backhoe Procedures

Pins and Bushings

Change pins (1) and bushings (2) when worn or damaged.

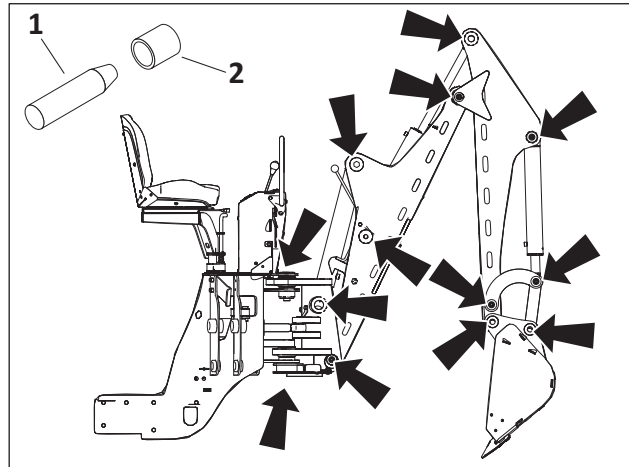

t63om049h21.eps

Microtrencher Maintenance Interval Chart*

▽	Adjust, service, or test	□	Change, initial	○	Lube, initial
▲	Check	■	Change	●	Lube

Service	10 Hours	100' (30.5m)	100 Hours	As Needed
Attachment mounting bolts	▲			
Blade and bits		▲		■
Deflectors	▲			▽
Level cylinder				▽
Slide plate	▲			
Tilt adjustment			●	
Traverse frame	▲			
Vacuum hose	▲			

*The chart above indicates the first instance of repeated service procedures. See detailed information below.

Microtrencher Procedures

Attachment Mounting Bolts

Check bolts (shown) every 10 hours.

1. Check for looseness or wear.
2. Apply Loctite® 271.
3. Tighten to 200ft•lb (271N•m).

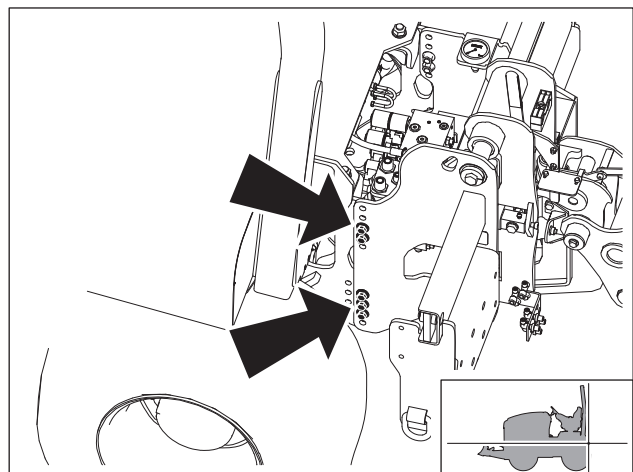

t63om050h21.eps

Blade and Bits

MT12

Check bits for wear every 100ft (30.5m). Replace worn bits as needed.

Check wear bars and hard-surface material on blades every 100ft (30.5m). Replace wear bars and hard-surface material as needed to protect bit holders. Change blade when bits, wear bars and hard-surface material can no longer be replaced.

Rotating Conical Bits

1. Check bit condition using gauge (shown, 301-1507).

A: Replace bits

B: Bits OK

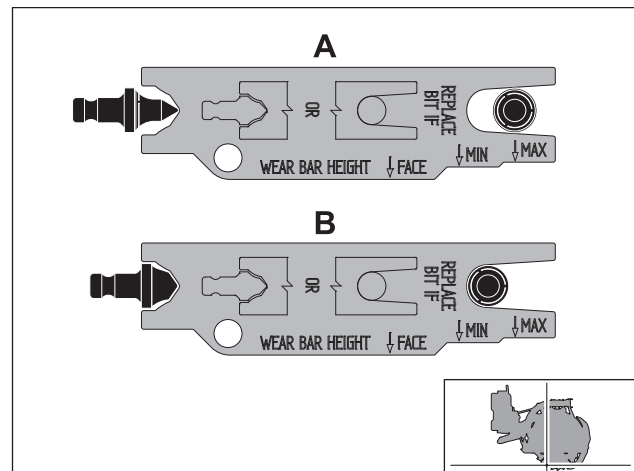

t28om081h.eps

2. As needed, drive out roll pin (2).
3. Remove bit (1).
4. Install new bit into holder.
5. Drive in new roll pin.

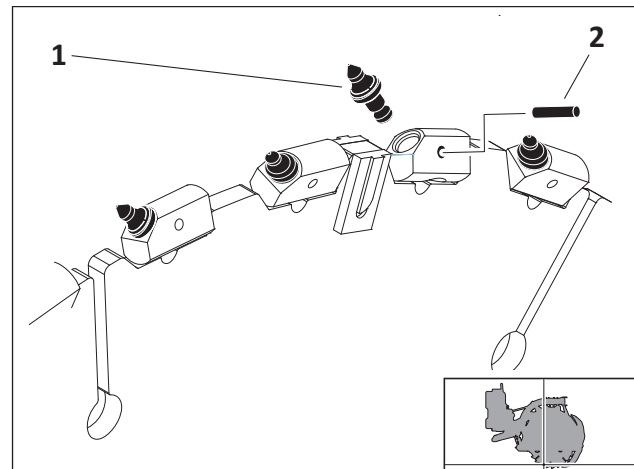

t61om016w19.eps

Wear Bars/Hard-Surface Material

Check thickness of wear bars and hard-surface material with gauge (shown, 301-1507). Replace material as needed.

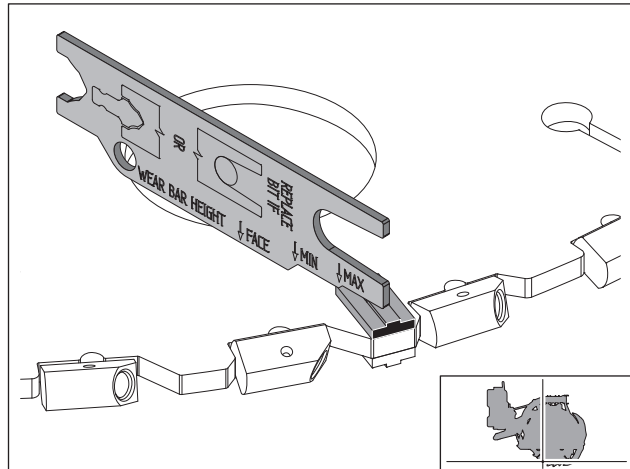

t28om082h.eps

Change Blade

1. Start engine.
2. Position microtrencher slightly above ground.
3. Shut off machine.
4. Remove 7 wingnuts (1), spanner wrench (2), and cover (3).

IMPORTANT: To keep blade from turning, insert prybar through cutout in blade.

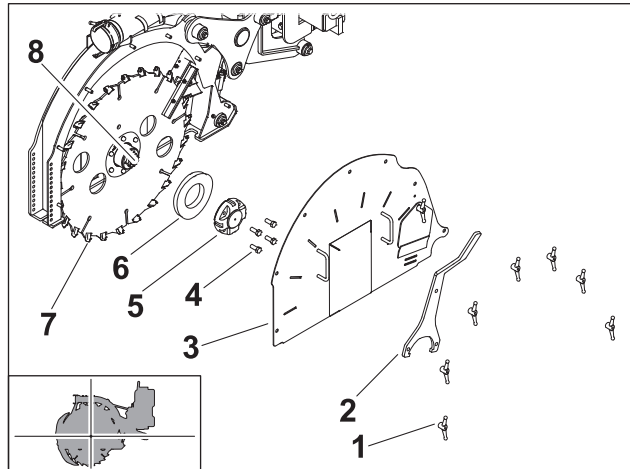

t28om077h.eps

5. Loosen clamp bolts (4) and remove large nut (5).
6. Remove spacer (6) and blade (7).
7. Clean threads on hub (8) and nut (6). If needed, apply dry lubricant such as graphite or silicone to threads.
8. Install new blade (note direction of rotation), spacer and large nut.
9. Fully tighten large nut.
10. Tighten clamp bolts to 100-120ft•lb (135-160N•m).
11. Loosen clamp bolts and repeat steps 8 and 9.
12. Install cover, spanner wrench, and wingnuts.

MT16

Check bits (shown) for wear every 100ft (30.5m). Change blade when bits are worn.

Fixed Bits

1. Remove blade cover.
2. Inspect all bits for wear.
3. Replace blade when bits are worn.

Change Blade

1. Start engine.
2. Position microtrencher slightly above ground.
3. Shut off machine.
4. Remove 6 wingnuts (1) from cover (2).
5. Remove 6 lug nuts (3).
6. Remove blade (4).
7. Clean threads (5).
8. Install new blade (note direction of rotation) and secure with 6 lug nuts.
9. Tighten lug nuts to 600ft•lb (813.5N•m).
10. Install cover and secure with wingnuts.

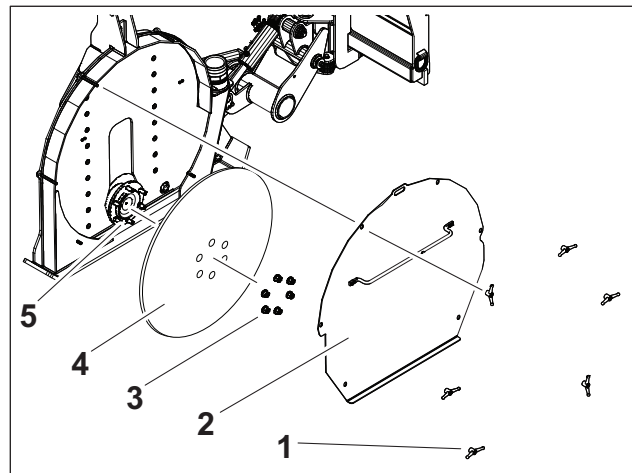

t52om002w.eps

Deflectors

MT12

Check deflectors (shown) every 10 hours when not using a vacuum for spoils removal.

Clean vacuum chute as needed.

Change spoils deflectors on saw frame, cover and spoils chutes as needed, making sure to orient spoils chute as indicated on decal.

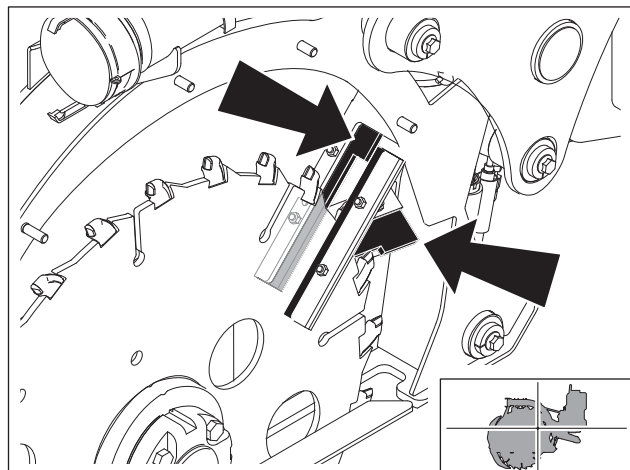

t28om074h.eps

Level Cylinder

Bleed air from level cylinder when hydraulic hoses have been disconnected and when saw bounces excessively.

1. Remove blade.
2. Start engine.
3. Fully retract level cylinder (1) until it is vertical.
4. Lower rear of microtrencher to just above the ground.
5. Shut off machine.
6. Connect jumper hose (2) to test ports on left side of microtrencher.
7. Start machine and select low speed.
8. Slowly extend level cylinder to full length. Hold lever there for 10 seconds to return trapped air to tank.
9. Slowly retract level cylinder. Hold lever for 10 seconds to return trapped air to tank.
10. Repeat steps 8 and 9.
11. Shut off machine.
12. Remove jumper hose.

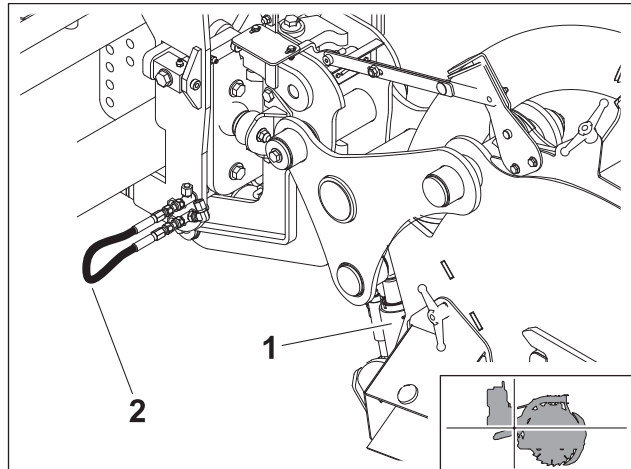

t28om078h.eps

Slide Plate

Check slide plate (shown) every 10 hours. Replace as needed.

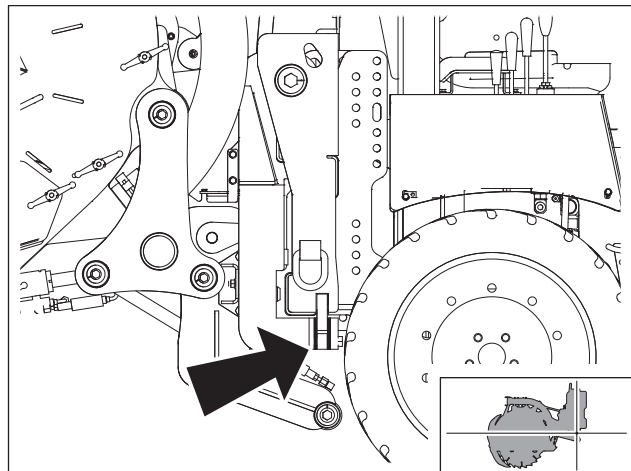

t28om073h.eps

Tilt Adjustment

MT12

Lube zerks (shown) with MPG every 100 hours.

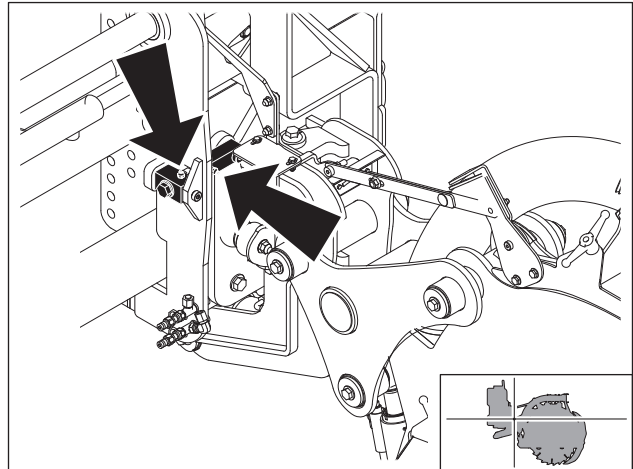

t28om076h.eps

Vacuum Hoses



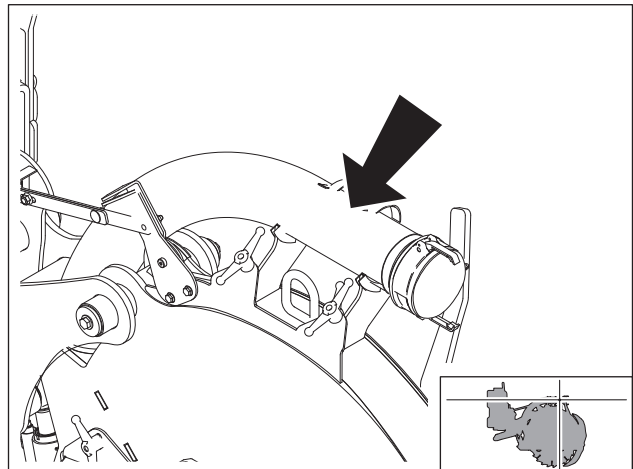



Check hoses (shown) every 10 hours. Clean out caked spoils as needed.



t28om075h.eps

Plow Maintenance Interval Chart*

Plow Maintenance Interval Chart*

	Adjust, service, or test		Change, initial		Lube, initial
	Check		Change		Lube

Service	10 Hours	50 Hours	100 Hours	250 Hours	500 Hours	1000 Hours	2000 Hours	As Needed
Arm pins and bushings	▲							
Attachment mounting bolts	▲							
Connector pivots	●							
Feed tube								▽
Lift cylinder		▲						
Oil, vibrator	▲	□			■			
Pivots	●							
Plow blade bolts								▲
Shear mounts			▲					■
Sod cutter and blade								■

*The chart above indicates the first instance of repeated service procedures. See detailed information below.

Plow Procedures

Arm Pins and Bushings

Check pins and bushings (shown) every 10 hours.
Tighten as needed.

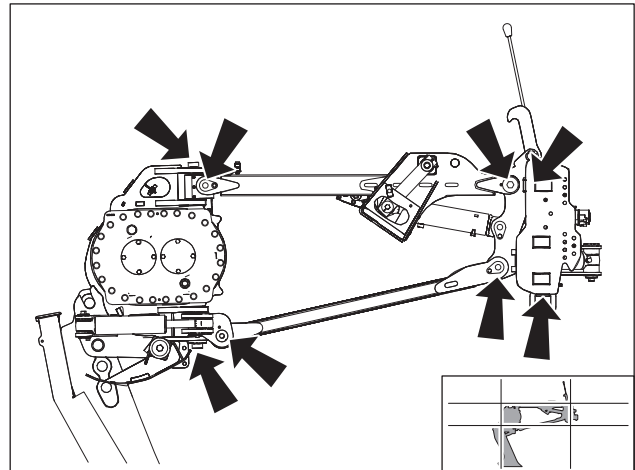

t63om051h21.eps

Attachment Mounting Bolts

Check bolts (shown) every 10 hours.

1. Check for looseness or wear.
2. Apply Loctite 271.
3. Tighten to 230ft•lb (312N•m).

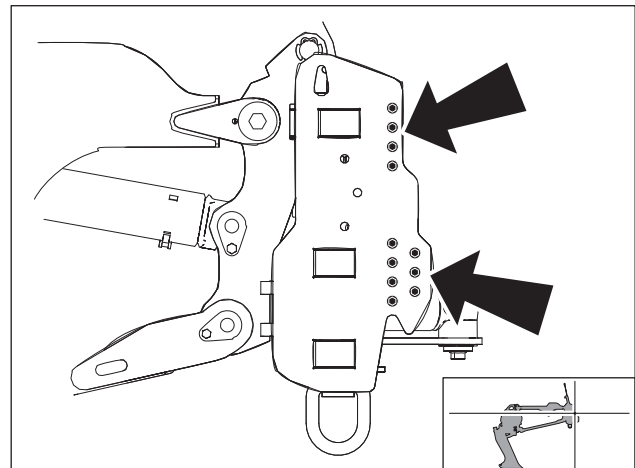

t63om052h21.eps

Connector Pivots

Check every 10 hours. Test upper and lower arm joints every 100 hours.

Check

Check pivots (shown) for wear or damage.

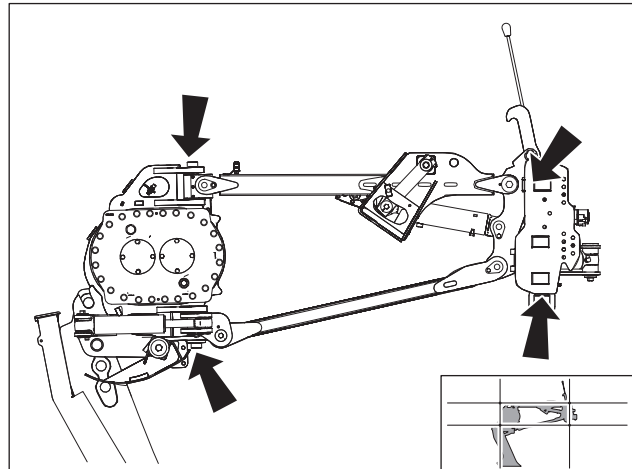

t63om053h21.eps

Test

Upper Arm Joints:

1. Lower plow to ground.
2. Use plow lift control to put hydraulic load on pivot joints. Do not raise plow.
3. As hydraulic load is applied and released, check joints for motion at joints (1). If motion is observed, contact your Ditch Witch dealer.

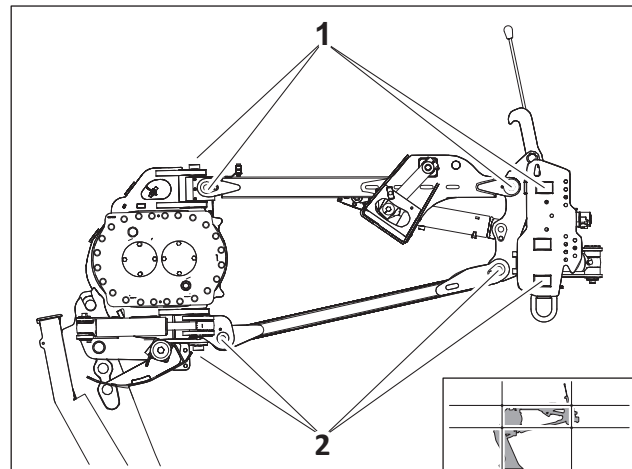

t63om054h21.eps

Lower Arm Joints:

1. Lower plow to ground.
2. Use hydraulic jack to place load on lower arm.
3. As hydraulic load is applied and released, check joints (2) for motion. If motion is observed, contact your Ditch Witch dealer.

Feed Tube

Clean feed tube (shown) as needed.

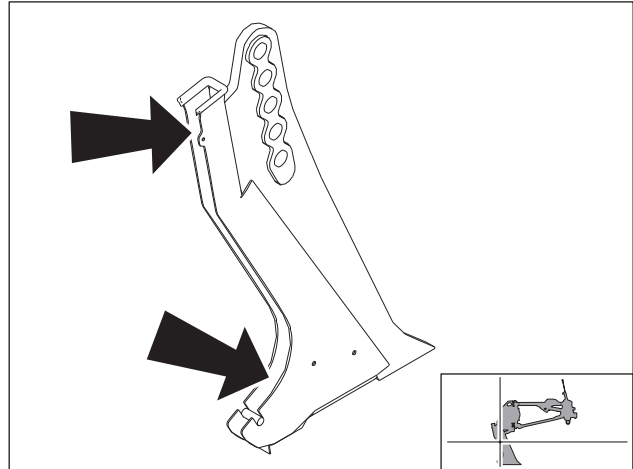

t63om055h21.eps

Lift Cylinder

Check pins and bumpers (shown) for wear every 50 hours. Replace as needed.

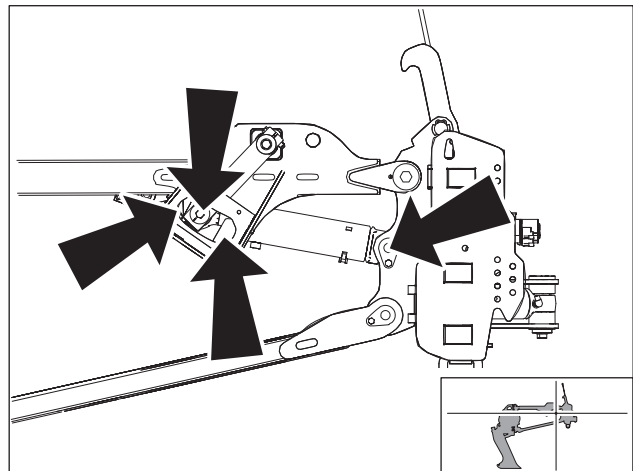

t63om056h21.eps

Oil, Vibrator

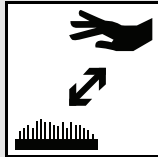

CAUTION Hot parts. Contact can cause burns. Only touch when cool or wear gloves.

NOTICE: Change every 250 hours if jobsite temperature 100°F (38°C) more than 50% of the time.

Check oil on each side of vibrator every 10 hours. Change after 50 hours and every 500 hours thereafter.

Check

1. With vibrator horizontal, check level at sight glass (1).
2. Add MPL at fill (2) as needed to keep level at halfway point on sight glass.

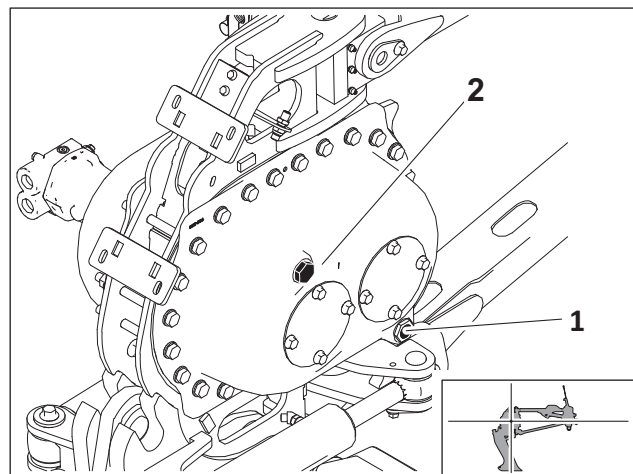

t63om057h21.eps

Change

1. Move plow vibrator to horizontal position.
2. Open fill (2) to vent vibrator.
3. Remove plug (3) to drain.
4. Install plug.
5. Add MPL at fill until level is at halfway point on sight glass.

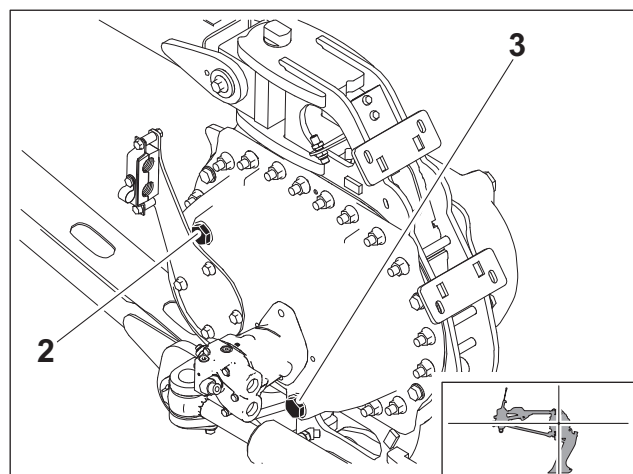

t63om058h21.eps

Pivots

Lube pivots (shown) with EPG every 10 hours.

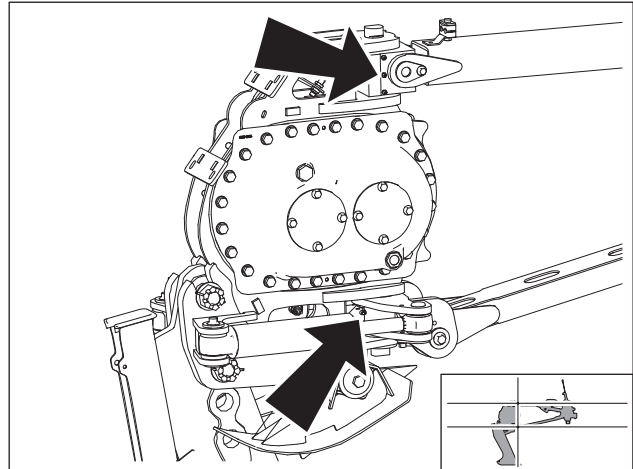

t63om059h21.eps

Plow Blade Bolts

Check bolts (shown) as needed.

1. Check for looseness.
2. Apply Loctite 242 (blue).
3. Tighten bolts to 210ft•lb (285N•m).

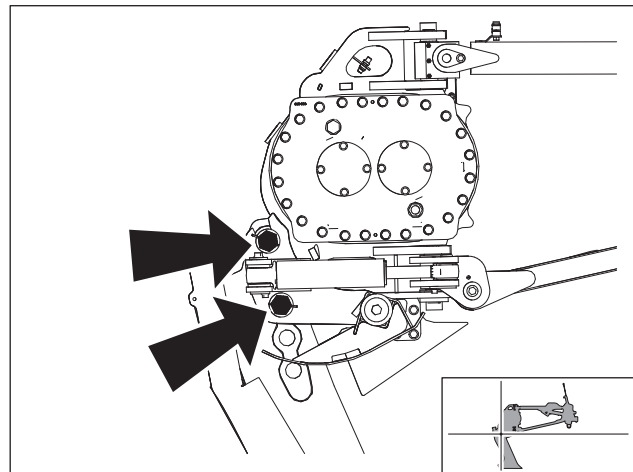

t63om060h21.eps

Shear Mounts

IMPORTANT: When replacing shear mounts, compress the mounts with washers to prevent the mount from tearing.

Check mounts (shown) every 100 hours. Replace as needed.

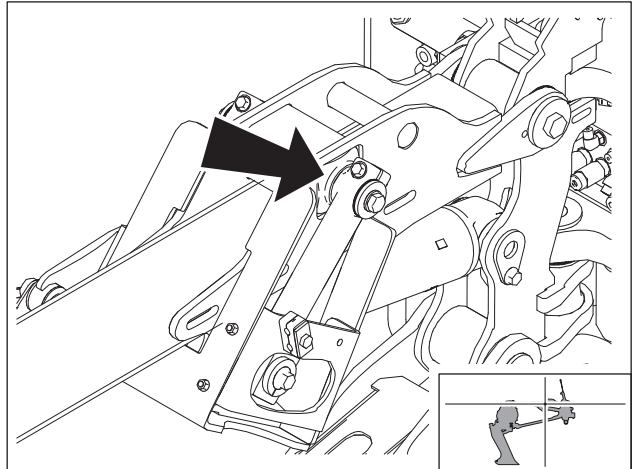

t63om061h21.eps





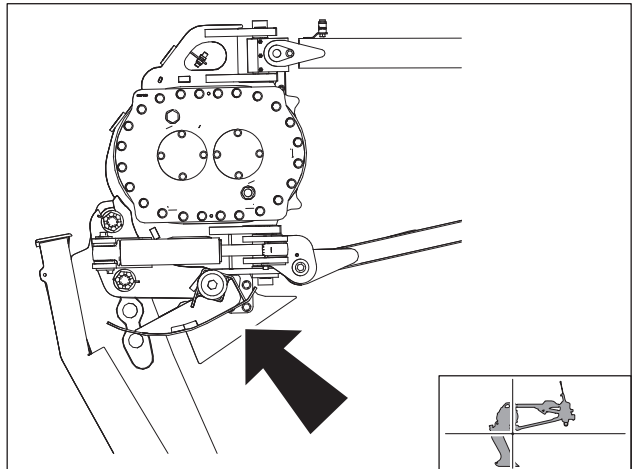

Sod Cutter and Blade

















Change sod cutter and blade (shown) as needed.



t63om063h21.eps

Trencher Maintenance Interval Chart*

 Adjust, service, or test	 Change, initial	 Lube, initial
 Check	 Change	 Lube

Service	10 Hours	50 Hours	500 Hours	1000 Hours	As Needed
Attachment mounting bolts					
Auger bearings					
Auger bolts					
Auger shaft					
Boom mounting bolts					
Digging chain					
Digging chain tension					
Headshaft motor shaft					
Oil, gearbox					
Personnel restraint bar/Trench cleaner bolts					
Pivot					
Restraint bar position					
Tail roller					
Trench cleaner position					

*The chart above indicates the first instance of repeated service procedures. See detailed information below.

Trencher Procedures

Attachment Mounting Bolts

Check bolts (shown) every 10 hours.

1. Check for looseness or wear.
2. Apply Loctite 271.
3. Tighten inner bolts (2) to 230ft•lb (312N•m).
4. Tighten outer bolts (1) to 449ft•lb (608N•m).

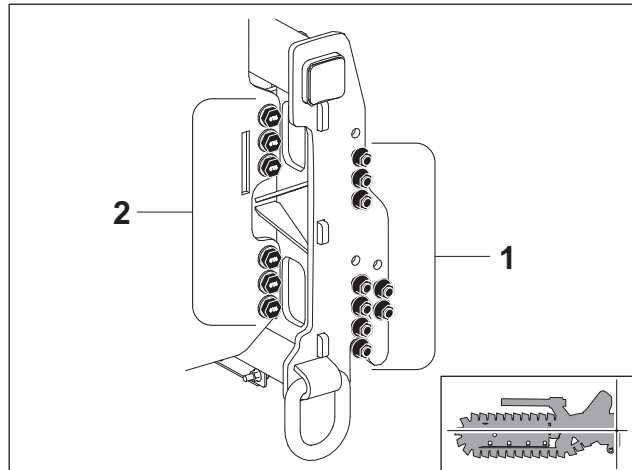

t63om063h21.eps

Auger Bearings

Lube two bearing zerks (one on each side, shown) with EPG every 10 hours.

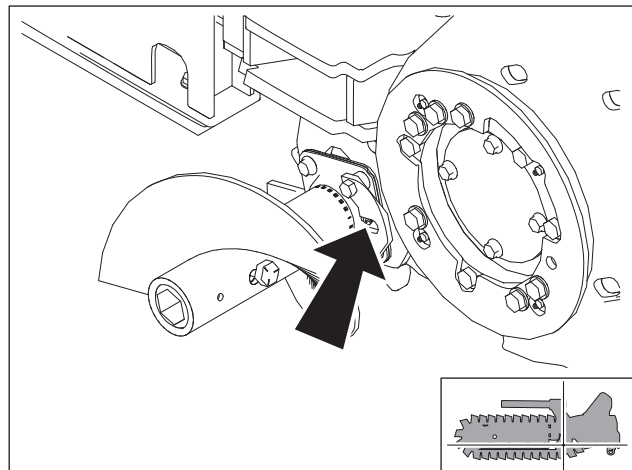

t63om064h21.eps

Auger Bolts

Check bolts every 10 hours. For optimal spoils delivery, adjust augers (shown) to match terrain and digging depth.

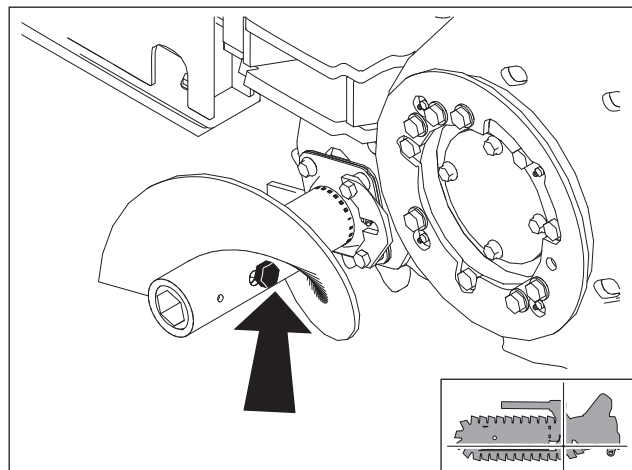

t63om065h21.eps

Auger Shaft

Lube two auger shaft zerks (one on each side, shown) with EPG every 10 hours.

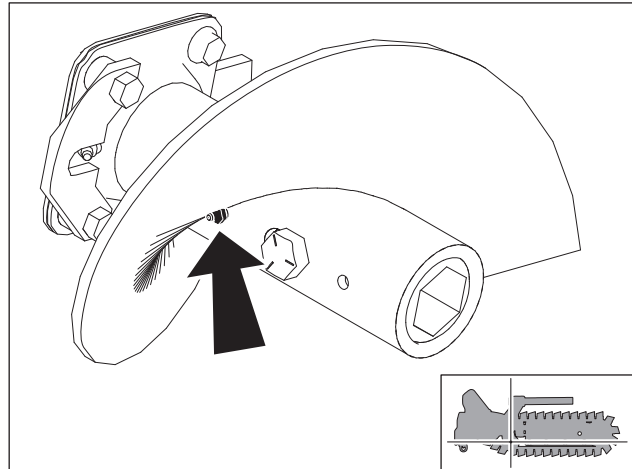

t63om066h21.eps

Boom Mounting Bolts

Check 5 bolts (shown) every 10 hours.

1. Check for looseness or wear.
2. Tighten to 250ft•lb (339N•m).

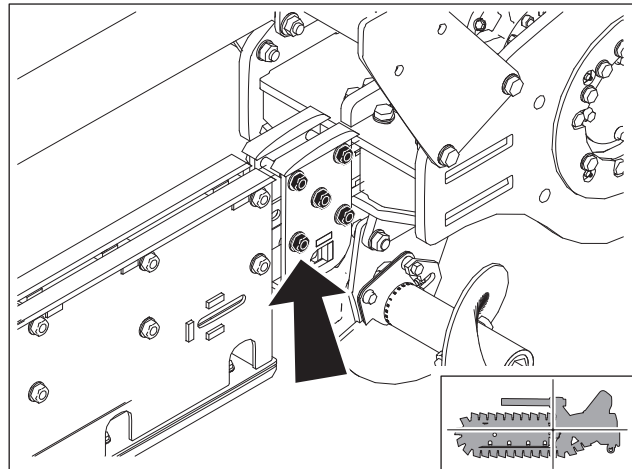

t63om067h21.eps

Digging Chain

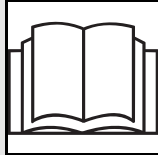

⚠ WARNING Contents under pressure. Impact can cause death or serious injury. Relieve pressure before opening.

To help avoid injury:

- Service digging boom grease cylinder only while standing on opposite side of boom.
- Cover connection with heavy cloth when relieving pressure in cylinder.

Check every 10 hours. Change digging chain as needed.

Check

Bits

1. If using rock chain bits, check that bits rotate freely.
2. Clean chain and check bits after each use.
3. Replace bit when carbide cap or insert is worn.

Pins and Bushings

Check pins and bushings for wear by measuring distance between chain pins (3) and comparing it with a new chain.

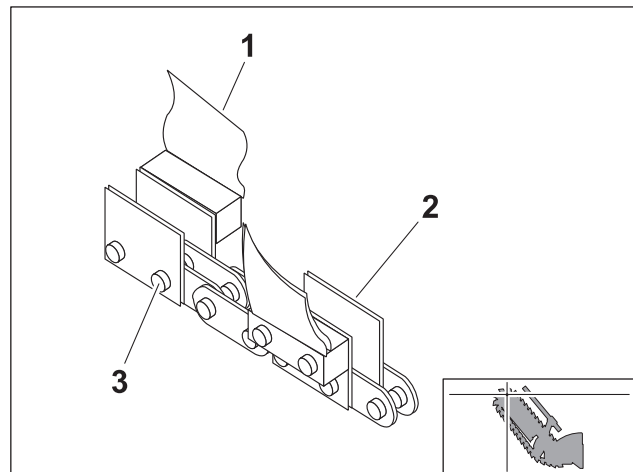

t30om055h.eps

Sidebars

If sidebars (2) are bent or loose on chain pins, chain spacers should be used to join sidebars.

Teeth

Check teeth (1) for wear.

NOTICE: Replace worn teeth using Ditch Witch replacement parts and maintaining original tooth pattern.

Change

NOTICE: Replace sprockets when a new chain is installed.

Remove Chain

1. Fasten and adjust seat belt.
2. Start engine.
3. Turn digging chain until connector pin is on top of boom.
4. Lower boom to ground.
5. Set parking brake.
6. Shut off machine.
7. Secure chain by clamping links on either side of connector pin with chain jaws as shown. Squeeze jaws to reduce pressure on connector pin.
8. Loop cable through links nearest connector pin.

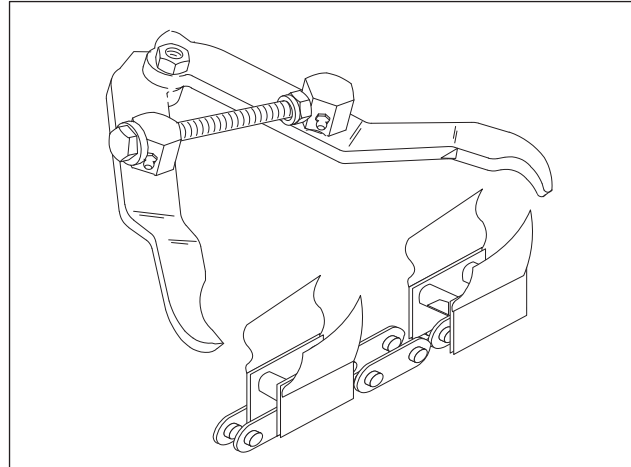

Digging_Chain_Remove_01.eps

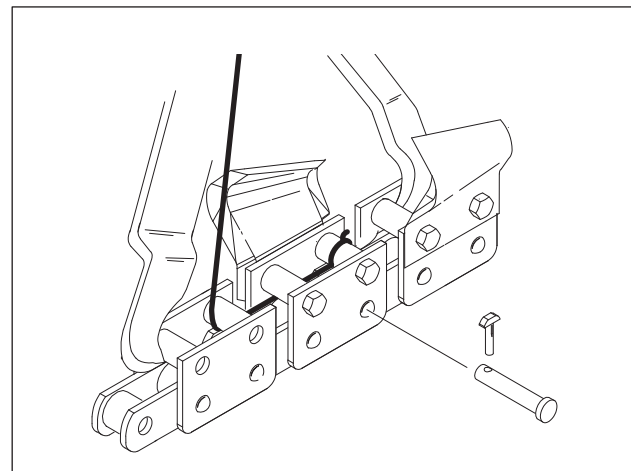

Digging_Chain_Remove_02.eps

Trencher Procedures

9. Loosen plug on grease cylinder or turn tension bolts (shown) counterclockwise to relieve chain tension.
10. Stand clear of chain and remove lock key from connector pin.
11. Drive connector pin out of link.
12. Unclamp links. Slowly release cable and lower chain to ground.

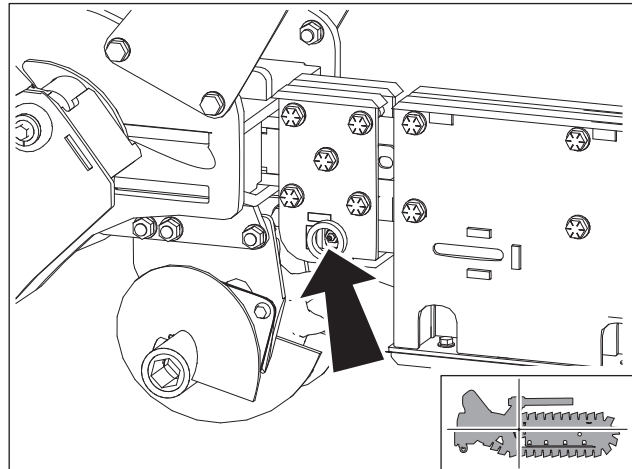

t630m068h21.eps

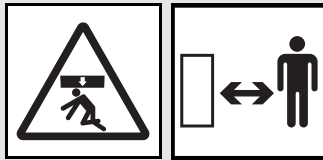

WARNING Raised component. Crushing can cause death or serious injury. Stay away. Use correct equipment and procedures.

13. Lay chain on ground with teeth down.

Install Chain

1. Lay chain on ground with teeth down and pointed toward unit.
2. Fasten and adjust seat belt.
3. Start engine.
4. Release parking brake.
5. Back unit up until chain extends past headshaft about 1' (305mm).
6. Stop machine movement.
7. Lower backfill blade, if equipped, to ground.
8. Lower boom to horizontal position.
9. Set parking brake.
10. Shut off machine.
11. Pull rear end of chain over and about 10" (260mm) past tail roller.
12. Use hoist to pull front end of chain over headshaft sprocket.
13. Move chain down boom until chain connector pin and lock key can be installed.
14. Install connector pin and lock key.
15. Tighten chain by pumping EPG into grease cylinder.

Time Augers

Ensure augers are balanced, as shown. If auger timing is off, machine will bounce from side to side even in normal digging conditions.

1. Remove bolts holding augers to auger shaft.
2. Rotate either auger as needed until augers are balanced.
3. Install bolts.
4. Tighten.

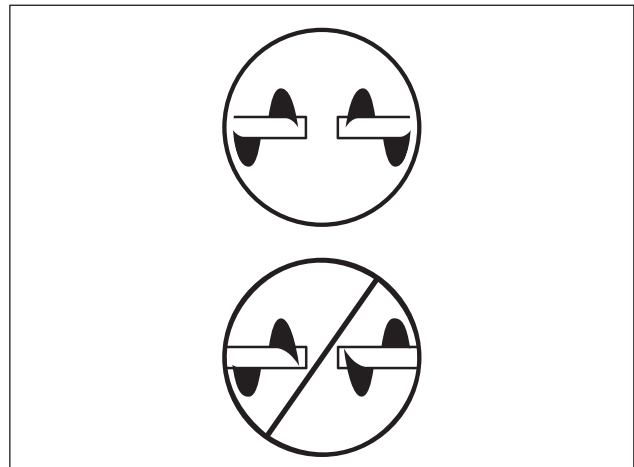

Augers_Adjust.eps

Digging Chain Tension

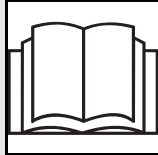

⚠ WARNING Contents under pressure. Impact can cause death or serious injury. Relieve pressure before opening.

To help avoid injury:

- Service digging boom grease cylinder only while standing on opposite side of boom.
- Cover connection with heavy cloth when relieving pressure in cylinder.

Check every 10 hours. Adjust as needed.

1. With boom horizontal, measure distance from bottom of boom to chain (2). When properly adjusted, distance should be 4.5-5.5" (114-140mm).
2. To tighten chain, lube cylinder (1) with MPG.

To relieve chain tension, loosen plug on grease cylinder.

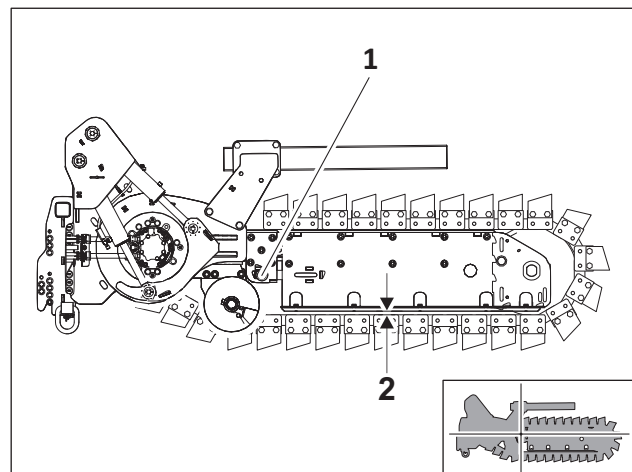

t63om069h21.eps

Headshaft Motor Shaft

Check headshaft motor shaft (shown) every 10 hours.

1. Check headshaft for wire or string wrapped around shaft at seal.
2. Carefully removed wrapped material.
3. Check for oil leaking from shaft seal.
4. If oil is leaking from motor shaft seal, check motor shaft for looseness in bearings.
5. Remove and replace motor if bearings are loose enough to allow oil to leak from seal.

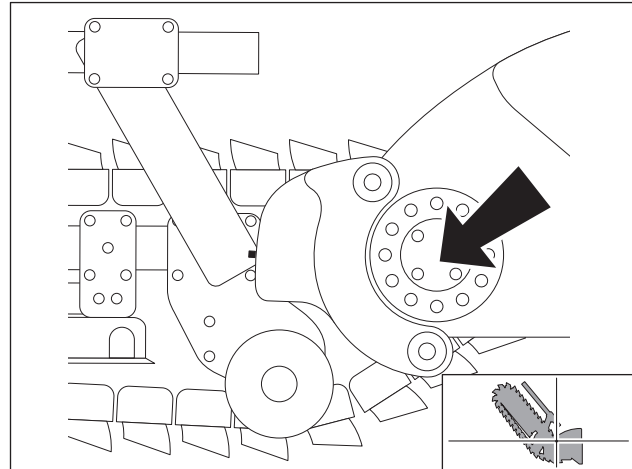

t30om062h.eps

Personnel Restraint Bar/ Trench Cleaner Bolts

Check all bolts securing restraint bar/trench cleaner to arm (4 on each side, shown) and arm to boom every 10 hours.

Check all bolts securing restraint bar/trench cleaner to machine every 10 hours.

1. Check for looseness or wear.
2. Apply Loctite® 271.
3. Tighten bolts holding personnel restraint bar/trench cleaner (shown) to 350ft•lb (475N•m).
4. Tighten bolts securing arm to boom to 400ft•lb (542N•m).

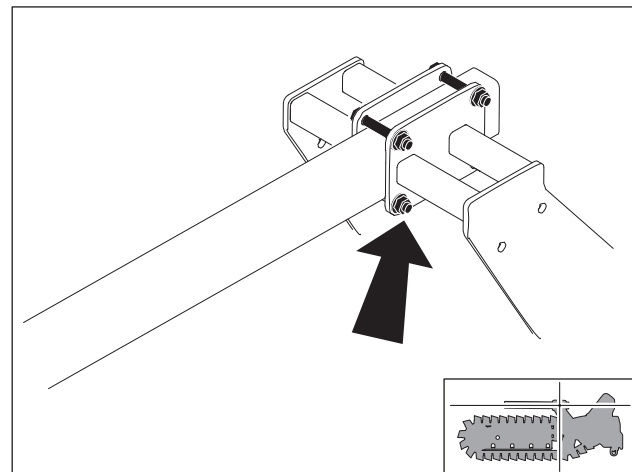

t63om070h21.eps

Pivot

Wipe four zerks (shown) located on right side of trencher pivot clean and lube with EPG every 10 hours.

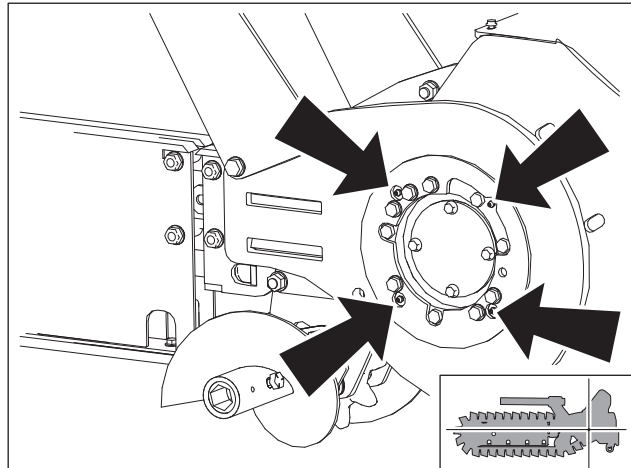

t63om071h21.eps

Wipe four zerks (shown) located on left side of trencher pivot clean and lube with EPG every 10 hours.

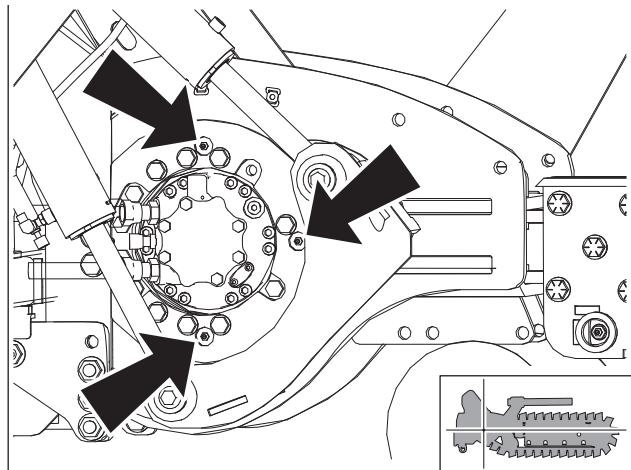

t63om091h21.eps

Restraint Bar Position

Check every 10 hours or anytime the digging chain is adjusted or replaced.

1. Ensure end of bar extends between the center of the tail roller/sprocket and the end of the digging chain.
2. Check for looseness or wear.

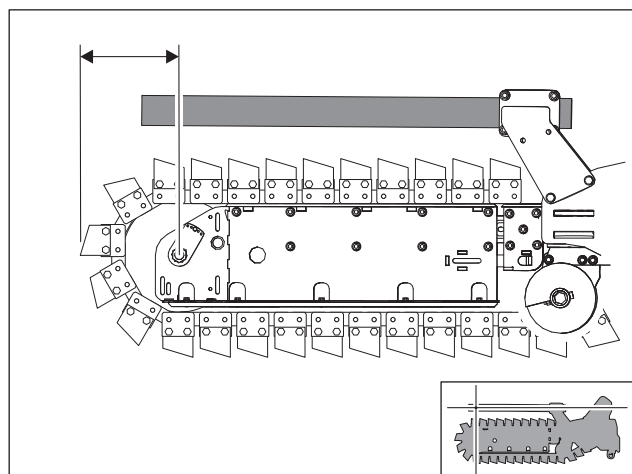

t63om072h21.eps

Tail Roller

Remove plug (shown) to access zerk. Clean and lube with EPG every 10 hours.

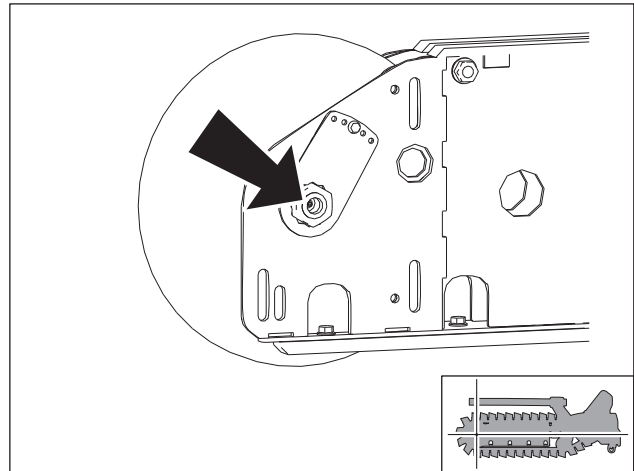

t63om073h21.eps

Trench Cleaner Position

Check trench cleaner position (if equipped) every 10 hours or anytime the digging chain is adjusted or replaced.

Ensure there is 3-4in (76-102mm) between the digging teeth and the inside of the trench cleaner shoe (A).

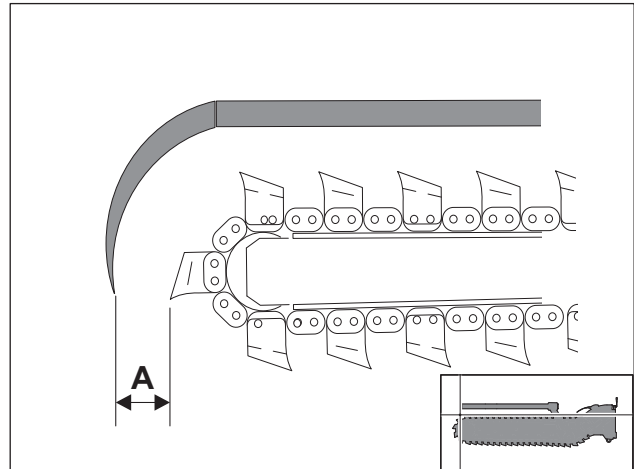

t33om90w.eps

Specifications

Chapter Contents

RT70 Tractor	196
BH70 Backhoe	205
CT70 Trencher	208
ST70 Trencher	210
VP70 Plow	212
MT12 Microtrencher	214
MT16 Microtrencher	216
RC20 Reel Carrier	218
EU Declaration of Conformity	219

RT70 Tractor

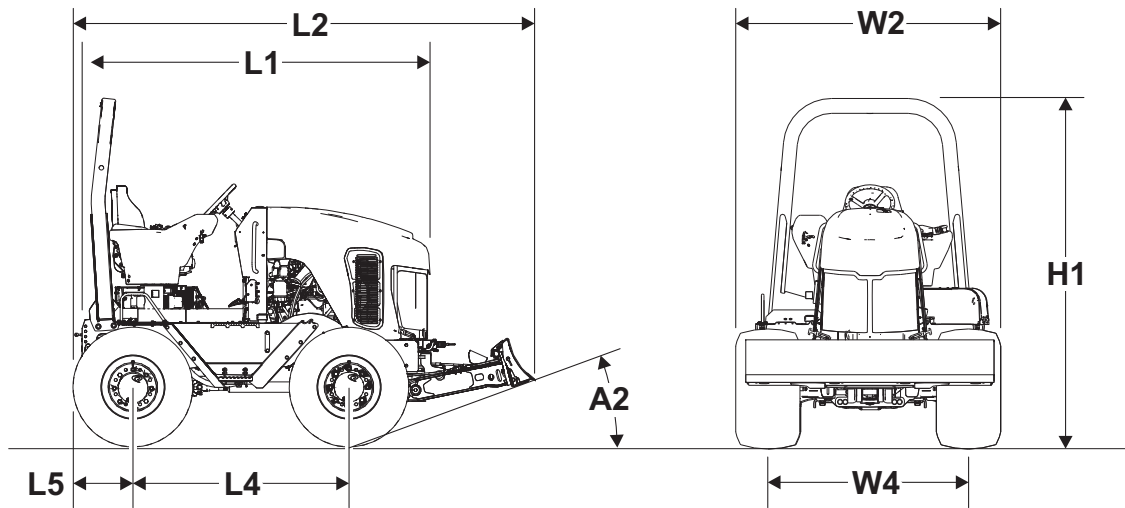

t63om074h21.eps

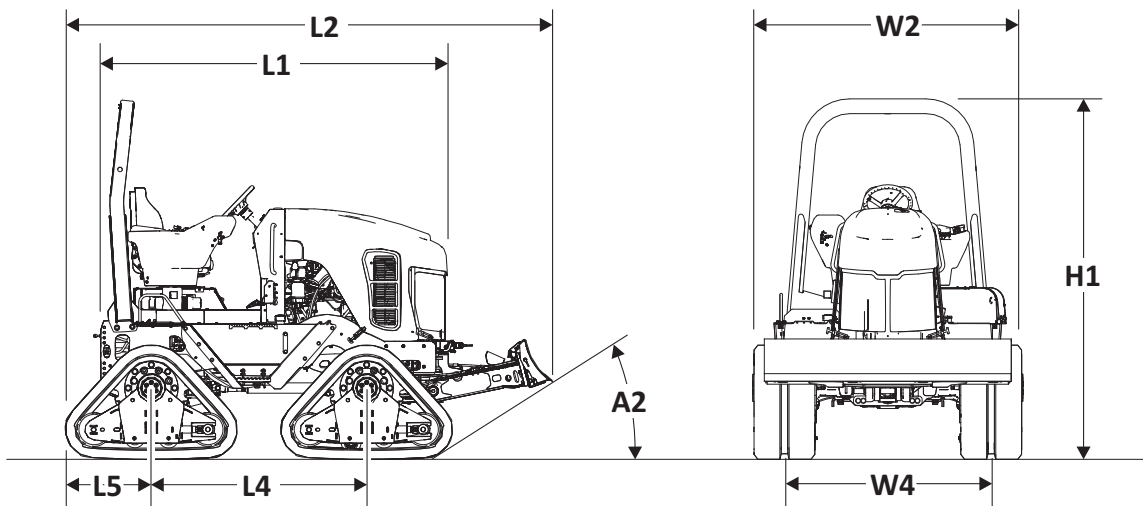

t63om075h21.eps

Dimensions		US	Metric
A2	Angle of approach, tracks	32°	32°
	Angle of approach, 19.0/45 tires	20.8°	20.8°
	Angle of approach, solid tires	19.3°	19.3°
H1	Height, tracks	104.4in	2.65m
	Height, 19.0/45 tires	100.6in	2.56m
	Height, solid tires	100.4in	2.55m
L1	Nose to rear mount length	101.5in	2.58m
L2	Length - transport, tracks	142.4in	3.62m
	Length - transport, 19.0/45 tires	134.8in	3.42m
	Length - transport, solid tires	133.5in	3.39m
L4	Wheelbase	63in	1.6m
L5	Rear axle to attachment mount holes	13.8in	351mm
W2	Width, tracks	78.5in	1.99m
	Width, 19.0/45 tires	76.8in	1.95m
	Width, solid tires	71.1in	1.81m
W4	Tread, tracks	60.3in	1.52m
	Tread, 19.0/45 tires	58.2in	1.48m
	Tread, solid tires	54.7in	1.39m

Operation		U.S.	Metric
Forward speeds			
tracks	Low/low	0.79mph	1.27km/h
	Low/medium	1.07mph	1.72km/h
	Low/high	1.72mph	2.77km/h
	High/low	2.29mph	3.69km/h
	High/medium	3.02mph	4.86km/h
	High/high	4.22mph	6.79km/h
19.0/45 tires	Low/low	1.21mph	1.95km/h
	Low/medium	1.47mph	2.37km/h
	Low/high	2.27mph	3.65km/h
	High/low	3.53mph	5.68km/h
	High/medium	4.29mph	6.9km/h
	High/high	6.52mph	10.49km/h
solid tires	Low/low	1.15mph	1.85km/h
	Low/medium	1.56mph	2.51km/h
	Low/high	2.69mph	4.33km/h
	High/low	3.55mph	5.71km/h
	High/medium	4.55mph	7.32km/h
	High/high	6.40mph	10.3km/h

Operation		U.S.	Metric
Reverse speeds			
tracks	Low/low	.77mph	1.24km/h
	Low/medium	1.06mph	1.71km/h
	Low/high	1.74mph	2.8km/h
	High/low	2.29mph	3.69km/h
	High/medium	3.02mph	4.86km/h
	High/high	4.22mph	6.79km/h
19.0/45 tires	Low/low	1.23mph	1.98km/h
	Low/medium	1.49mph	2.4km/h
	Low/high	2.28mph	3.67km/h
	High/low	3.55mph	5.71km/h
	High/medium	4.29mph	6.9km/h
	High/high	5.62mph	9.04km/h
solid tires	Low/low	1.15mph	1.85km/h
	Low/medium	1.58mph	2.54km/h
	Low/high	2.70mph	4.35km/h
	High/low	3.37mph	5.42km/h
	High/medium	4.57mph	7.24km/h
	High/high	5.40mph	8.69km/h

Operation	U.S.	Metric
Vehicle clearance circle (SAE) wall to wall with optional backfill blade		
tracks	34.99ft	10.66m
19.0/45 tires	31.58ft	9.63m
solid tires	31.28ft	9.53m
Vehicle clearance circle (SAE) wall to wall with optional backfill blade, front and rear steer		
tracks	24.68ft	7.52m
19.0/45 tires	23.64ft	7.21m
solid tires	21.85ft	6.66m
Ground clearance		
tracks	14.94in	379mm
19.0/45 tires	11.15in	283mm
solid tires	9.13in	232mm

Operation		U.S.	Metric
Basic unit weight			
	tracks (no bfb)	9590lb	4350kg
	19.0/45 tires (no bfb)	6000lb	2722kg
	solid tires (no bfb)	6489lb	2943kg
Max allowable tractor weight		17,000	7711kg

Front counterweight rack (Rack + 15x96 lbs cast weights)	1710lb	776kg
Front axle trunnion angle (level to full tilt; 1/2 of full rot)	5.2°	5.2°
Rear axle tilt angle (level to full tilt; 1/2 of full rot)	no tilt	
Track articulation angle	15°	15°
Front axle steer angle	35°	35°
Rear axle steer angle	23°	23°

Backfill Blade	U.S.	Metric
Blade width	72in	1829mm
Blade height	14.9in	378mm
Lift height above ground	22.7in	577mm
Blade drop below ground	9.4in	239m
Maximum swint angle (left/right)	30°	30°
Tilt angle (full cw/ccw)	20°	20°

Engine		U.S.	Metric
Yanmar 4TNV98CT		600lb	272kg
Fuel		Diesel	
Cooling medium		Liquid	
Injection		Direct	
Aspiration		Turbocharged	
Number of cylinders		4	
Displacement		202.53in ³	3.319L
Bore		3.85in	98mm
Stroke		4.33in	110mm
Engine manufacturer's gross power rating per SAE J1995		72.01hp	53.7kW
Estimated net power per SAE J1349		62.71hp	46.76kW
Rated speed		2500rpm	2500rpm
Emissions compliance		EPA Tier 4, EU Stage V	

Power Train	
Ground drive transmission	Two speed transmission with three speed bent axis motor
Differentials	Planetary steering front and rear with diff loc
Service brake	Hydrostatic
Parking brake	SAHR
Tires	19.0/45-17 14PR TL
Tires with urethane	19.0/45-17 14PR TL
Tires, Solid	33 x 12
Tracks	450 x 85 x 36 rubber track w/ chevron pattern
Attachment drive	Hydrostatic

Hydraulic System		U.S.	Metric
Ground drive pump capacity at 2500rpm		29gpm	110 L/min
Ground drive pump relief pressure at 2500 rpm		4350-4800psi	300-330bar
Attachment pump capacity at 2500rpm		29gpm	110L/min
Attachment pump forward relief pressure at 2500rpm		5800-6400psi	400-440bar
Auxilliary pump capacity @ 2500 rpm			
	Steering pump	7.2gpm	27.5L/min
	Auxilliary pump	7.2gpm	27.5L/min
	Side of engine (BH70 supplementary pump)	6.5gpm	24.5L/min
Auxilliary pump relief pressure @ 2500 rpm		3000psi	207bar
Fluid Capacities		U.S.	Metric
Fuel tank		25gal	95L
Engine oil		11.1qt	10.5L
Hydraulic reservoir		18gal	68L
Hydraulic system		24gal	90L
Cooling system		3.3gal	12.3L

Battery, 2 used

Group 78U, SAE res. cap 115min., SAE cold crank @ 0°F (-18°C), 800amp, dual battery option

Auxiliary power outlet - 12volt, 10amp

Vibration Levels	Plowing	Trenching
Average vibration transmitted to the operator's hand during normal operation	13.1m/sec ²	4.2m/sec ²
Average vibration transmitted to the operator's whole body during normal operation	0.6m/sec ²	0.9m/sec ²

Operator seat per ISO 7096

Actual vibration levels depend on the conditions of the operation being performed.

Noise Level

Operator 91 dbA sound pressure per ISO 6394

Exterior 107 dbA sound power per ISO 6393.

This machine can generate sound levels exceeding 80dBA. Always wear appropriate hearing protection when operating machine. Find sound power and pressure information at www.ditchwitch.com, or contact customersupport@ditchwitch.com.

Specifications are called out according to SAE recommended practices. Specifications are general and subject to change without notice. If exact measurements are required, equipment should be weighed and measured. Due to selected options, delivered equipment may not match that shown.

BH70 Backhoe

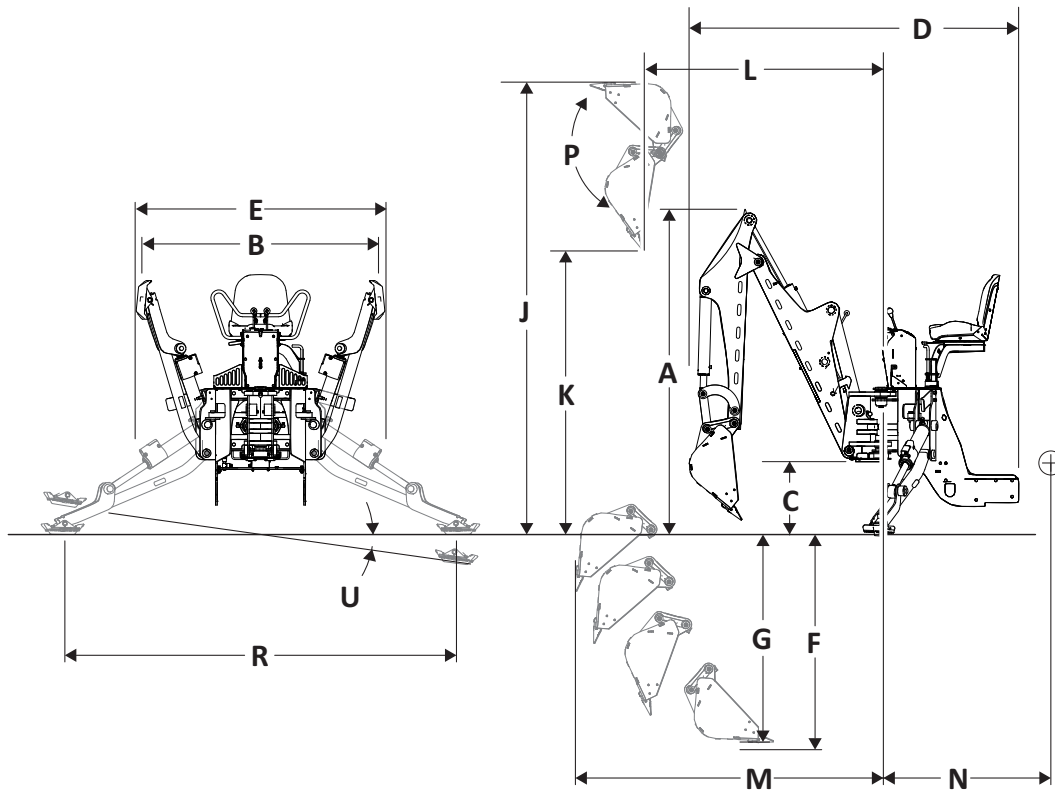

t63om076h21.eps

Dimensions		US	Metric
A	Transport height, tracks	114.6in	2911mm
	Transport height, 19.0/45 tires	110.8in	2814mm
B	Stabilizer spread, transport	61in	1549mm
C	Ground clearance, tracks	38.4in	975mm
	Ground clearance	34.6in	879mm
D	Backhoe length, stowed	101.2in	2570mm
E	Backhoe or basic unit width, tracks	78.5in	1994mm
	Backhoe or basic unit width, 19.0/45	76.3in	1938mm
F	Digging depth, max, tracks	89.2in	2266mm
	Digging depth, max, 19.0/45 tires	93in	2362mm
G	Digging depth, 2ft (0.6m) flat bottom, tracks	84.7in	2151mm
	Digging depth, 2ft (0.6m) flat bottom, 19.0/45 tires	88.5in	2248mm

Dimensions		US	Metric
J	Operating height, fully raised, tracks	149.6in	3800mm
	Operating height, fully raised, 19.0/45 tires	145.8in	3703mm
K	Loading height, tracks	99.8in	2535mm
	Loading height, 19.0/45 tires	96in	2438mm
L	Loading reach	66.5in	1689mm
M	Reach from swing pivot, tracks	140in	3556mm
	Reach from swing pivot, 19.0/45 tires	141in	3581mm
N	Swing pivot to centerline axle	46in	1168mm
P	Bucket rotation	154°	154°
R	Stabilizer spread, operating	103in	2616mm
U	Leveling angle, tracks	6°	6°
	Leveling angle, 19.0/45	7°	7°

General		U.S.	Metric
Bucket			
	Width	12-18in	305-460mm
	Capacity	1.7-2.6ft ³	0.05-0.07m ³
Backhoe weight without bucket		2215lb	1005kg
Vertical force, boom over end and swing arc, SAE *			
	@48in (1.2m)	1685lb	764kg
	@ground level	1685lb	764kg
	@72in (1.84m)	1600lb	726kg
Vertical force, dipperstick over end and swing arc, SAE *			
	@53in (1.4m)	2870lb	1302kg
	@72in (1.8m)	2890lb	1311kg
Swing arc		170°	170°

General	U.S.	Metric	
Max tool force			
	Using bucket cylinder	4200lb	18.68kN
	Using arm cylinder	4000lb	17.79kN

*Vertical forces are for a stationary machine supported by stabilizers.

CT70 Trencher

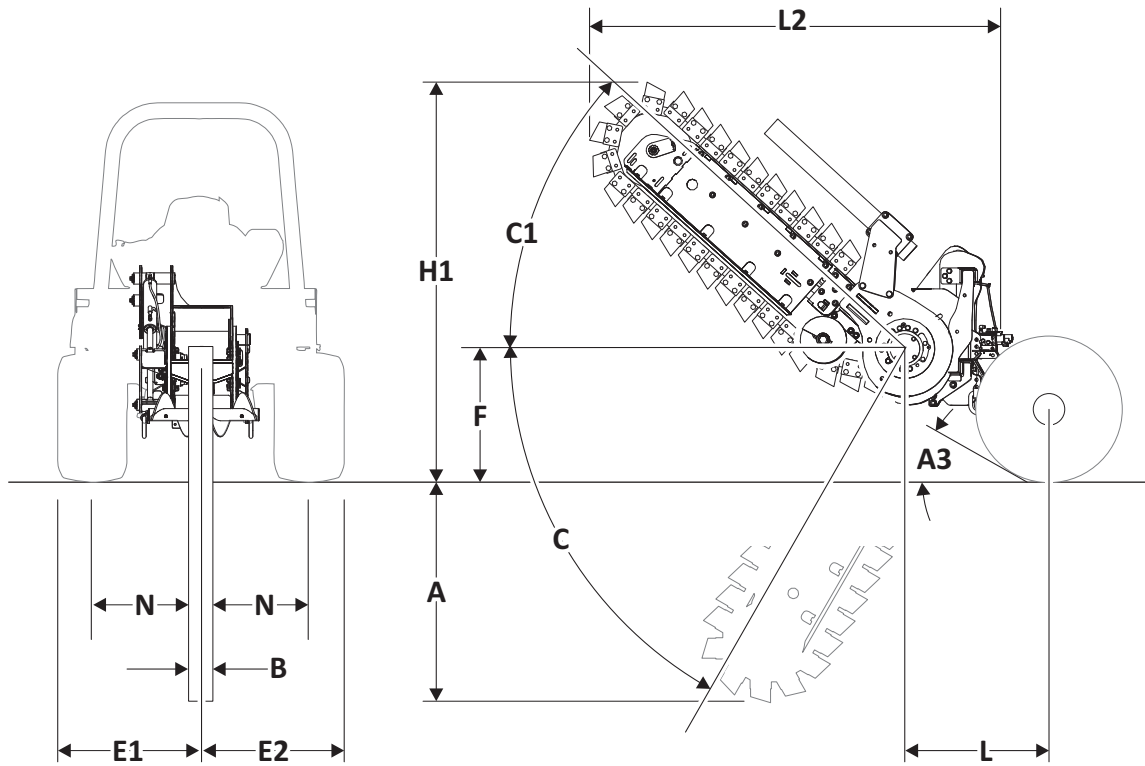

t63om096h21.eps

Dimensions		US	Metric
A3	Angle of departure, tracks	31.8°	31.8°
	Angle of departure, 19.0/45 tires	20.8°	20.8°
A	Trench depth, max, tracks	57.5in	1461mm
	Trench depth, max, 19.0/45 tires	61in	1549mm
B	Trench width, max	12in	305mm
	Trench width, max	6in	150mm
C	Boom travel down	61°	61°
C1	Boom travel up	43°	43°
E1	Centerline of trench to outside edge, left	39.9in	1013mm
	Centerline of trench to outside edge, left	39in	991mm
E2	Centerline of trench to outside edge, right	38.8in	986mm
	Centerline of trench to outside edge, right	38in	965mm

Dimensions		US	Metric
F	Headshaft height, digging chain, tracks	33in	838mm
	Headshaft height, digging chain, 19.0/45 tires	29.2in	742mm
H1	Transport height, tracks	108.4in	2753mm
	Transport height, 19.0/45 tires	104.5in	2654mm
L2	Transport length	107in	2718mm
L	Headshaft overhang	35.6in	904mm
N	Soil discharge reach from center of trench, short auger	18.5in	470mm
	Soil discharge reach from center of trench, long auger	31.6in	803mm
Attachment weight (without boom, chain, augers, stub, and restraint bar)		1240lb	562kg

Operation		U.S.	Metric
Headshaft speeds at 2500 engine rpm			
	Ratio low	210rpm	210rpm
	Ratio standard	235rpm	235rpm
	Ratio high	290rpm	290rpm
Digging chain speeds with 11-tooth, 3.110" (79mm) pitch headshaft sprocket			
	Ratio low	607ft/min	185m/min
	Ratio standard	679ft/min	207m/min
	Ratio high	838ft/min	255m/min

ST70 Trencher

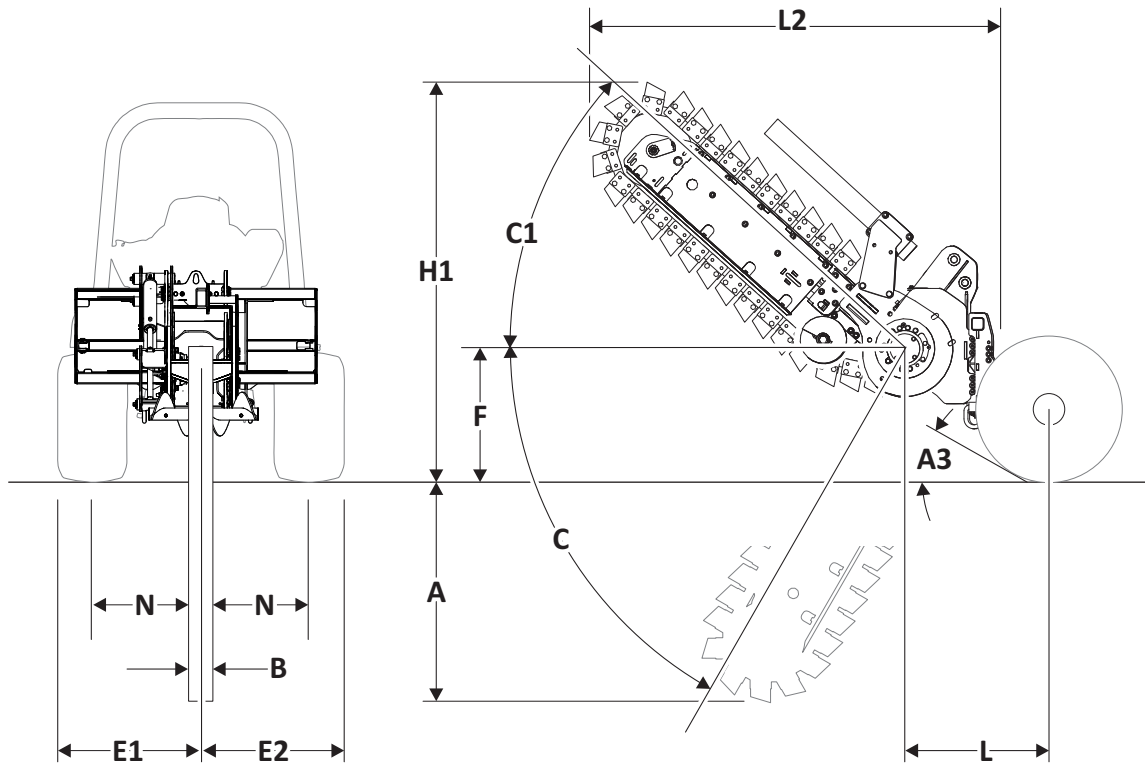

t63om077h21.eps

Dimensions		US	Metric
A	Trench depth, max, tracks	59.9in	1521mm
	Trench depth, max, 19.0/45 tires	63.8in	1621mm
A3	Angle of departure, tracks	24.4°	24.4°
	Angle of departure, 19.0/45 tires	17.9°	17.9°
B	Trench width, max	12in	305mm
	Trench width, min	6in	150mm
C	Boom travel down	61°	61°
C1	Boom travel up	43°	43°
E1	Centerline of trench to outside edge, left, tracks	15.8-39in	401-991mm
	Centerline of trench to outside edge, left, 19.0/45 tires	14.2-38.2in	361-970mm
E2	Centerline of trench to outside edge, right, tracks	15.6-39.6in	142-1501mm
	Centerline of trench to outside edge, right, 19.0/45 tires	14.7-38.7in	373-983mm

Dimensions		US	Metric
F	Headshaft height, digging chain, tracks	30.8in	782mm
	Headshaft height, digging chain, 19.0/45 tires	27in	686mm
H1	Transport height, tracks	106.1in	2692mm
	Transport height, 19.0/45 tires	104in	2642mm
L	Headshaft overhang	46.4in	1179mm
L2	Transport length	115.4in	2931mm
N	Soil discharge reach, short auger	18.5in	470mm
	Soil discharge reach, long auger	31.6in	803mm
	Attachment weight (without boom, chain, augers, stub, and restraint bar)	1730lb	785kg

Operation		U.S.	Metric
Headshaft speeds at 2500 engine rpm			
	Ratio low	210rpm	210rpm
	Ratio standard	235rpm	235rpm
	Ratio high	290rpm	290rpm
Digging chain speeds with 11-tooth, 3.110" (79mm) pitch headshaft sprocket			
	Ratio low	607ft/min	185m/min
	Ratio standard	679ft/min	207m/min
	Ratio high	838ft/min	255m/min

VP70 Plow

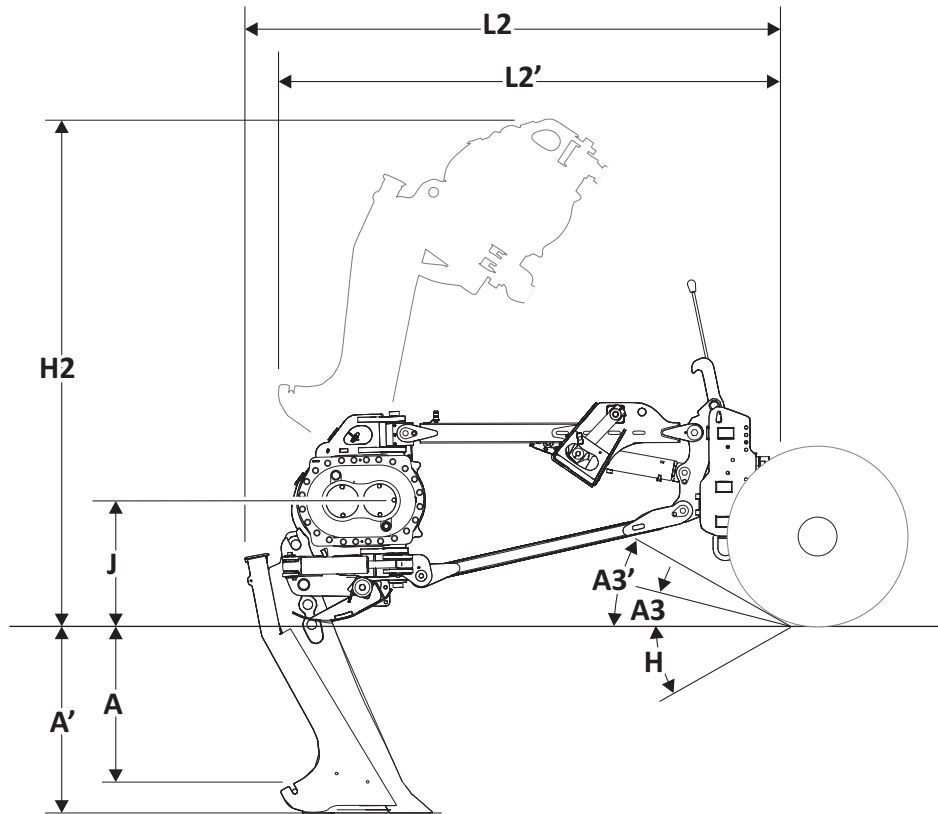

t630m078h21.eps

Dimensions		US	Metric
A	Cover depth*	36in	914mm
A'	Penetration*	40in	1020mm
A3	Angle of departure, transport, 24in (610mm) blade, tracks	25.5°	25.5°
	Angle of departure, transport, 24in (610mm) blade, 19.0/45 tires	32.7°	32.7°
	Angle of departure, transport, 30in (760mm) blade, tracks	20.3°	20.3°
	Angle of departure, transport, 30in (760mm) blade, 19.0/45 tires	27.3°	27.3°
A3'	Angle of departure, transport, no blade, tracks	48°	48°
	Angle of departure, transport, no blade, 19.0/45 tires	42°	42°
H	Angle of depression, plow max, tracks	7°	7°
	Angle of depression, plow max, 19.0/45 tires	7°	7°

Dimensions		US	Metric
H2	Height, transport, tracks	101.7in	2583mm
	Height, transport, 19.0/45 tires	97.8in	2484mm
J	Blade ground clearance, 30in (760mm) blade, tracks	36.8in	935mm
	Blade ground clearance, 30in (760mm) blade, 19.0/45 tires	32.9in	836mm
L2	Attachment length, fully lowered, no blade	94.1in	2390mm
L2'	Attachment length, fully raised, no blade	70.9in	1801mm
	Center of plow to outside edge of machine, left, tracks	39.4in	1001mm
	Center of plow to outside edge of machine, left, 19.0/45 tires	38.7in	983mm
	Center of plow to outside edge of machine, right, tracks	39.4in	1001mm
	Center of plow to outside edge of machine, right, 19.0/45 tires	38.7in	983mm
	Inclusive blade steer angle	89°	89°
	Plow swing angle	85°	85°

*Suggested maximum. Plow blade used will be determined by job requirements and soil conditions.

Operation		U.S.	Metric
Plow vibrator force @1800rpm		30,000lb	133kN
Max material diameter			
	Pulled	3in	76.2mm
	Fed	2in	50.8mm

Operation		U.S.	Metric
Attachment weight without plow blade and no counterweight		2044lb	907kg

MT12 Microtrencher

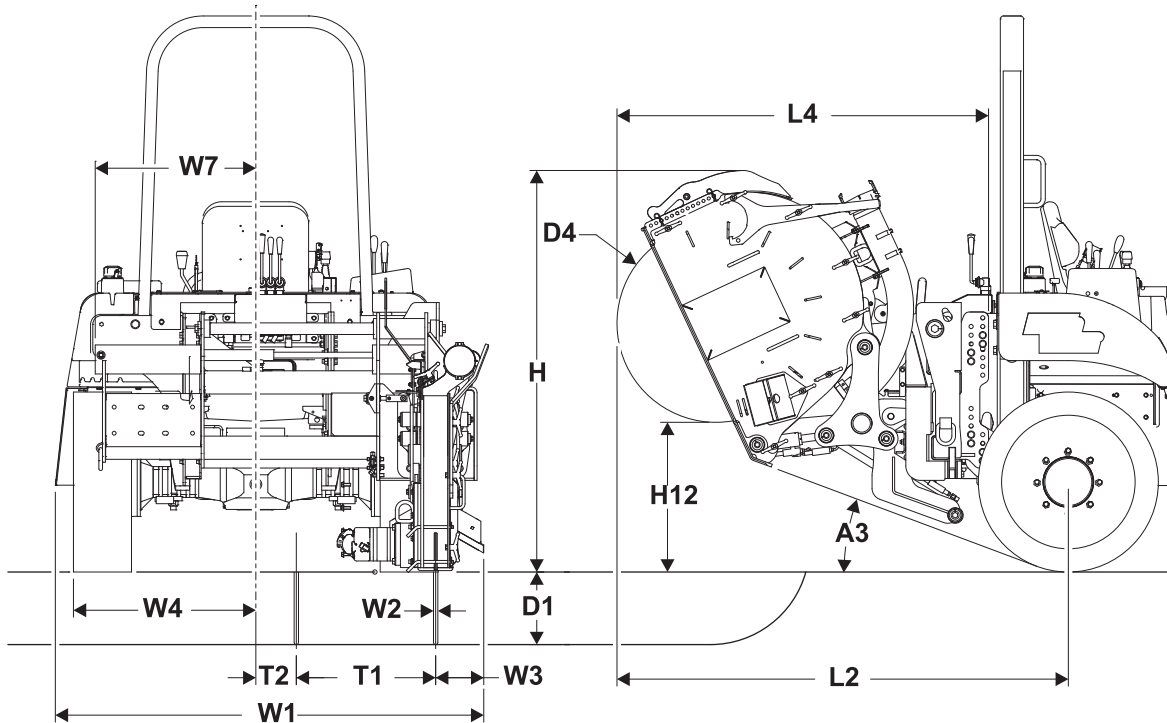

t24om005h.eps

Dimensions		US	Metric
A3	Angle of departure	17°	17°
D1	Trench depth	6.5-12.5in	165-318mm
D4	Blade diameter	34in	864mm
H	Attachment height, transport	63.3in	1608mm
H12	Ground clearance at wheel	24.4in	620mm
L2	Length, transport, from centerline of rear axle	76.4in	1941mm
L4	Length, transport, from front of attachment	64.1in	1628mm
T1	Microtrencher offset distance	24in	610mm
T2	Centerline of saw to centerline of machine, min offset	6.3in	160mm
W1	Working width, max	74.2in	1885mm
W2	Trench width	0.5-1.5in	13-38mm
W3	Spoils chute extension (same on both sides)	8.5in	216mm
W4	Centerline of machine to outside of left tire	32.7in	830mm

Dimensions		US	Metric
W7	Centerline of machine to end of traverse frame	28.3in	718mm
	Width, transport	71.1in	1806mm
	Length, working, from centerline of rear axle	84in	2.1m
	Attachment weight, including mount kit	1592lb	722kg
	Microtrenching radius, min, offset to right*	28.8ft	10.7m
	Microtrencher tilt adjustment	±6°	±6°

* Minimum sawing radius will depend on surface conditions and hardness of material being cut. Cut will be slightly wider in curved sections of the trench.

Operation	U.S.	Metric
Blade speed, variable	0-225rpm	0-225rpm
Microtrencher motor displacement	29.3in ³	480cc

Vibration Level

Average vibration transmitted to the operator's hand during normal operation is 5.2m/sec². Average vibration transmitted to the operator's whole body during normal operation does not exceed 0.32m/sec².

MT16 Microtrencher

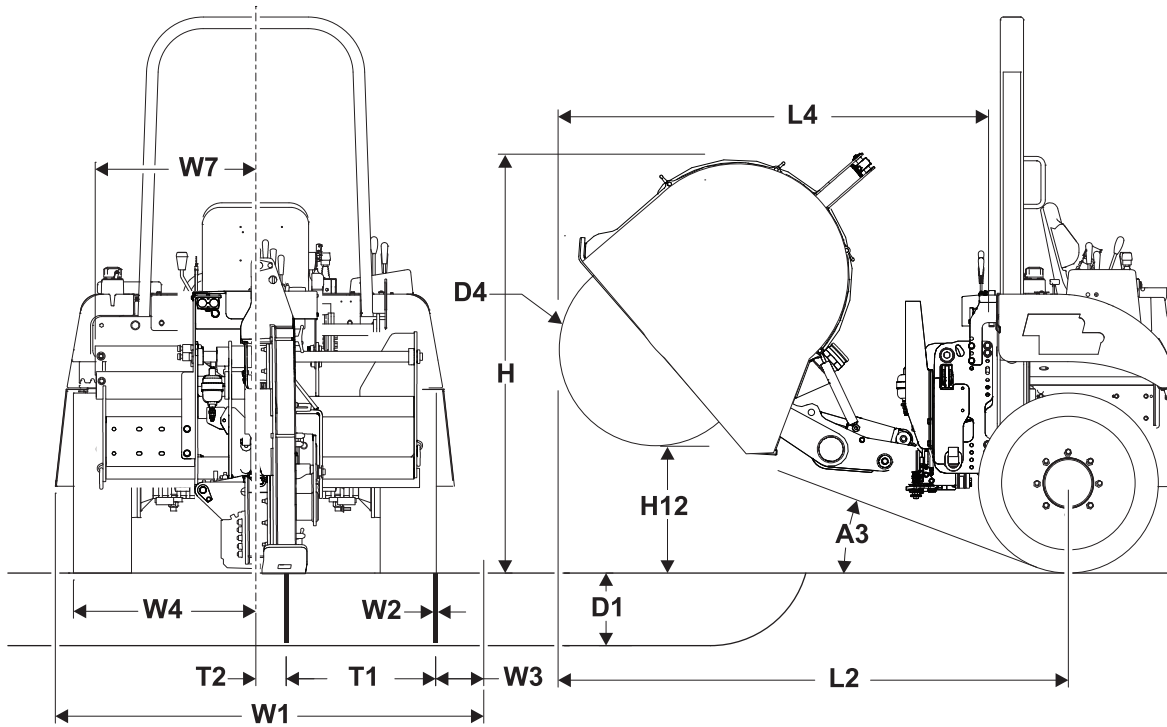

a52om001w.eps

Dimensions		US	Metric
A3	Angle of departure	20°	20°
D1	Trench depth, 1in (25.4mm) increments	0-16in	0-406mm
D4	Blade diameter	43in	1092mm
H	Attachment height, transport	81.4in	2068mm
H12	Ground clearance at wheel	11.8in	300mm
L2	Length, transport, from centerline of rear axle	94.2in	2393mm
L4	Length, transport, from front of attachment	81.4in	2068mm
T1	Microtrencher offset distance	24in	610mm
T2	Centerline of saw to centerline of machine, min offset	6.3in	160mm
W1	Working width, max	74in	1880mm
W2	Trench width	0.5-1.5in	13-38mm
W3	Spoils chute extension (right side)	16in	406mm
W4	Centerline of machine to outside left tire, 32x11 solid tires	32.7in	831mm

Dimensions		US	Metric
W7	Centerline of machine to end of traverse frame	27.7in	704mm
	Width, transport	71.1in	1806mm
	Length, working, from centerline of rear axle	111in	2.8m
	Attachment weight, including mount kit	2227lb	1010kg
	Microtrenching radius, min, offset to right*	24.5ft	7.5m
	Microtrencher tilt adjustment	±6°	±6°

* Minimum sawing radius will depend on surface conditions and hardness of material being cut. Cut will be slightly wider in curved sections of the trench.

Operation	U.S.	Metric
Blade speed, variable	0-139rpm	0-139rpm
Microtrencher motor displacement	47.6in ³	780cc

Vibration Level

Average vibration transmitted to the operator's hand during normal operation is 5.2m/sec². Average vibration transmitted to the operator's whole body during normal operation does not exceed 0.32m/sec².

RC20 Reel Carrier

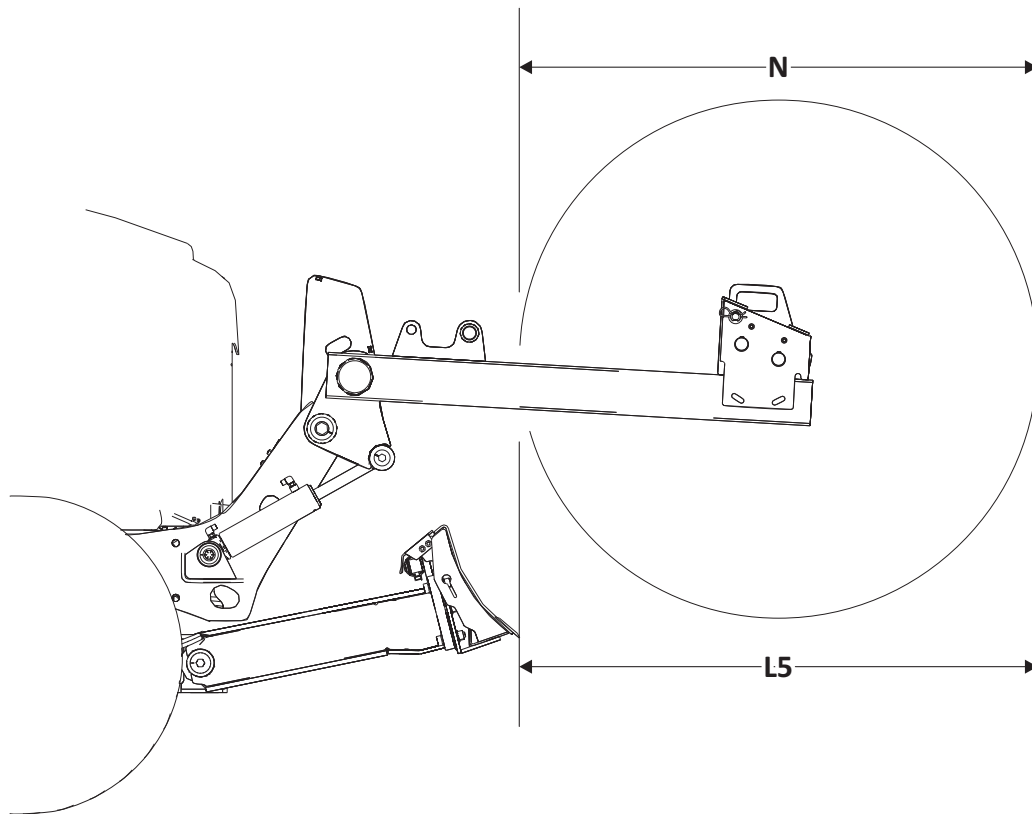

t630m079h21.eps

Dimensions		US	Metric
L5	Distance from backfill blade to outside edge of reel carrier with max diameter reel	72.5in	1842mm
N	Reel diameter, max	84in	2134mm
	Attachment weight	649lb	294kg
	Attachment weight with reel winder	799lb	362kg
	Capacity	2000lb	907kg
	Internal width	54in	1372mm

EU Declaration of Conformity

Countries in the European Union should have received a Declaration of Conformity (DOC) with this machine similar to the example below.

The Charles Machine Works, Inc.
PO Box 66
1959 West Fir Avenue
Perry, Oklahoma, USA 73077-0066
Phone: 580 572 3784
FAX: 580 572 3525

Declares that the product:

Model: Ditch Witch® XXXX
Type: (Machine Type)
Engine Power: xxx kW
Serial Number: DWPXXXXXXXXXXXXXXXXX

Conforms to the requirements of:

2006/42/EC Machinery Directive
2014/30/EU Electromagnetic Compatibility Directive
2000/14/EC Noise Emission Directive
Measured sound power level (Annex V): **XXXdBA**
Guaranteed sound power level (Annex V): **XXXdBA**

The Technical Construction File is maintained at the manufacturer's location.

The manufacturer's European representative is:

Ditch Witch Barcelona
International Underground Systems, S.L.
C/EL PLA, 130 *Poligon Industrial El Pla
08980 Sant Feliu De Llobregat *Spain
Phone: +34 93 632 7344
FAX: +34 93 632 7343

Support

Registration

If your equipment was purchased through a Ditch Witch dealer, it is already registered. If you purchased from any other source, please email productsupportwarrantyadmin@ditchwitch.com or fill out the registration card located in the back of the parts manual. Registration enables you to receive updates on this equipment as well as information on new products of interest.

Procedure

Notify your dealer immediately of any malfunction or failure of Ditch Witch equipment.

Always give model, serial number, and approximate date of your equipment purchase. This information should be recorded and placed on file by the owner at the time of purchase.

Return damaged parts to dealer for inspection and warranty consideration if in warranty time frame.

Order genuine Ditch Witch replacement or repair parts from your authorized Ditch Witch dealer. Use of another manufacturer's parts may void warranty consideration.

Resources

Publications

Contact your Ditch Witch dealer for publications and videos covering safety, operation, maintenance, and repair of your equipment.

Ditch Witch Training

For information about on-site individualized training, contact your Ditch Witch dealer.

Warranty

Ditch Witch Equipment and Replacement Parts Limited Warranty Policy

Subject to the limitation and exclusions herein, free replacement parts will be provided at any authorized Ditch Witch dealership for any Ditch Witch equipment or parts manufactured by the Ditch Witch factory that fail due to a defect in material or workmanship within one (1) year of first commercial use. Free labor will be provided at any authorized Ditch Witch dealership for installation of parts under this warranty during the first year following "initial commercial" use of the serial-numbered Ditch Witch equipment on which it is installed. The customer is responsible for transporting their equipment to an authorized Ditch Witch dealership for all warranty work.

Exclusions from Product Warranty

- All incidental or consequential damages.
- All defects, damages, or injuries caused by misuse (including, but not limited to, rollover), abuse, improper installation, alteration, neglect, or uses other than those for which products were intended.
- All defects, damages, or injuries caused by improper training, operation, or servicing of products in a manner inconsistent with manufacturer's recommendations.
- All engines and engine accessories (these are covered by original manufacturer's warranty).
- Tires, belts, and other parts which may be subject to another manufacturer's warranty (such warranty will be available to purchaser).
- ALL IMPLIED WARRANTIES NOT EXPRESSLY STATED HEREIN, INCLUDING ANY WARRANTY OF FITNESS FOR A PARTICULAR PURPOSE AND MERCHANTABILITY.

IF THE PRODUCTS ARE PURCHASED FOR COMMERCIAL PURPOSES, AS DEFINED BY THE UNIFORM COMMERCIAL CODE, THEN THERE ARE NO WARRANTIES WHICH EXTEND BEYOND THE FACE HEREOF AND THERE ARE NO IMPLIED WARRANTIES OF ANY KIND WHICH EXTEND TO A COMMERCIAL BUYER. ALL OTHER PROVISIONS OF THIS LIMITED WARRANTY APPLY INCLUDING THE DUTIES IMPOSED.

Ditch Witch products have been tested to deliver acceptable performance in most conditions. This does not imply they will deliver acceptable performance in all conditions. Therefore, to assure suitability, products should be operated under anticipated working conditions prior to purchase.

Defects will be determined by an inspection within thirty (30) days of the date of failure of the product or part by Ditch Witch Product Support (DWPS) or its authorized dealer. DWPS will provide the location of its inspection facilities or its nearest authorized dealer upon inquiry. DWPS reserves the right to supply remanufactured replacement parts under this warranty as it deems appropriate.

Extended warranties are available upon request from your local Ditch Witch dealer or the Ditch Witch factory.

Some states do not allow exclusion or limitation of incidental or consequential damages, so above limitation of exclusion may not apply. Further, some states do not allow exclusion of or limitation of how long an implied warranty lasts, so the above limitation may not apply. This limited warranty gives product owner specific legal rights and the product owner may also have other rights which vary from state to state.

For information regarding this limited warranty, contact the DWPS department, P.O. Box 66, Perry, OK 73077-0066, or contact your local dealer.